

SEQUEL[®] 20 6101/6103

DESK/COMPACT DESK

INSTRUCTION MANUAL

LET'S GET STARTED.

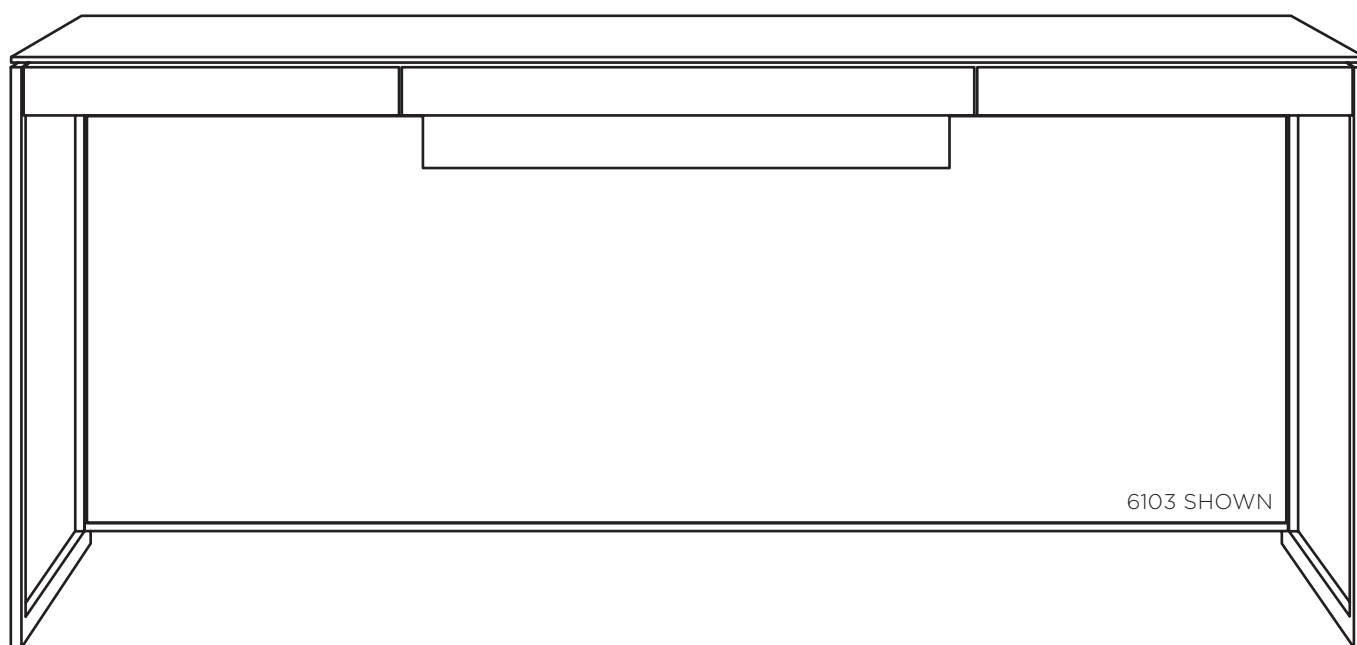

6103 SHOWN

DESIGN MATTHEW WEATHERLY

BDi

BDIUSA.COM



Congratulations on the purchase of your Sequel 20 Desk 6101 / Compact Desk 6103 from BDI. Your desk has been designed to provide a lifetime of enjoyment. This manual will provide you with assembly instructions and other helpful information that will ensure that you get the most out of your desk. Please save it for future reference.

Your Sequel 20 Desk has been engineered for simple assembly. Please follow these directions carefully to prevent any damage.

Should you need further assistance, contact BDI at customerservice@bdiusa.com.

ENJOY!

HARDWARE AND COMPONENTS

Unpack and identify the parts listed below. The assembly workspace should be a non-marring surface such as carpet. For missing hardware pieces, please contact BDI Customer Service at customerservice@bdiusa.com.

Do not use power tools for assembly of this product.

For all other concerns, please contact your BDI retailer.



PART #	T1
DESCRIPTION	Hex Wrench
QUANTITY	1

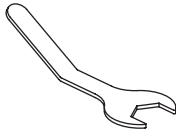

PART #	T2
DESCRIPTION	Hex Wrench
QUANTITY	1



PART #	H1
DESCRIPTION	M6 x 15mm Screw
QUANTITY	22



PART #	H2
DESCRIPTION	Leveler
QUANTITY	4

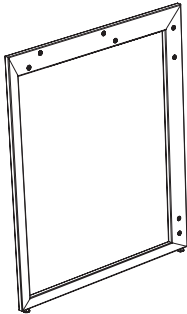

PART #	C1
DESCRIPTION	Left Leg Frame
QUANTITY	1

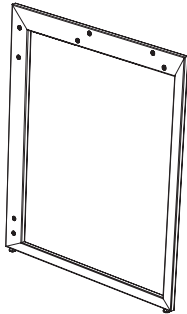

PART #	C2
DESCRIPTION	Right Leg Frame
QUANTITY	1

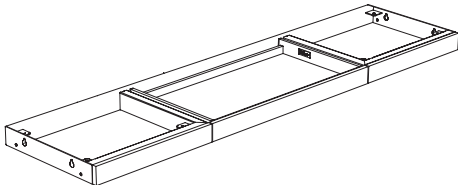

PART #	C3
DESCRIPTION	Drawer Assembly
QUANTITY	1

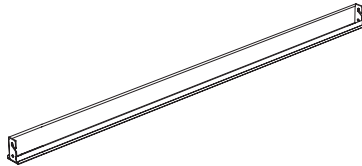

PART #	C4
DESCRIPTION	Lower Horizontal Frame
QUANTITY	1

HARDWARE AND COMPONENTS

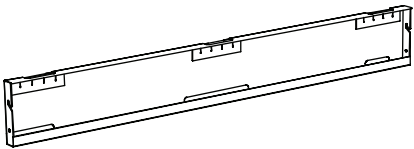

PART #	C5
DESCRIPTION	Upper Horizontal Frame
QUANTITY	1

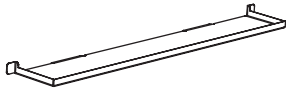

PART #	C6
DESCRIPTION	Wire Tray
QUANTITY	1

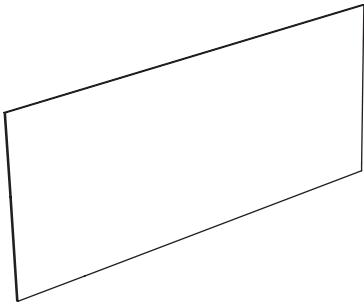

PART #	C7
DESCRIPTION	6108 Back Panel* see Note in Step 9
QUANTITY	1

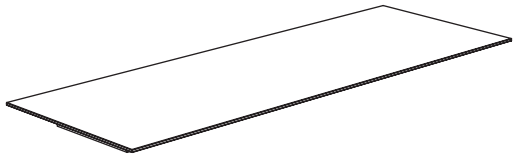

PART #	C8
DESCRIPTION	Top Panel
QUANTITY	1

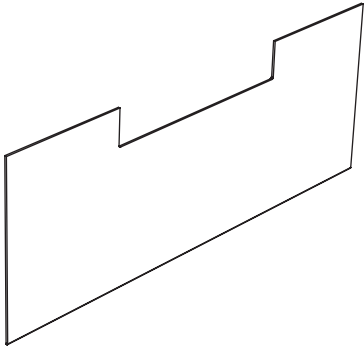

PART #	C9
DESCRIPTION	Front Panel
QUANTITY	1

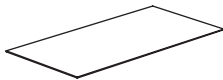

PART #	C10
DESCRIPTION	Drawer Liner
QUANTITY	1

ASSEMBLY

STEP 1. INSTALL LEVELERS

Install **(H2) Levelers** into the bottom of **(C1) Left** and **(C2) Right Leg Frames**.

	PART/DESCRIPTION	QTY
	H2-LEVELER	4

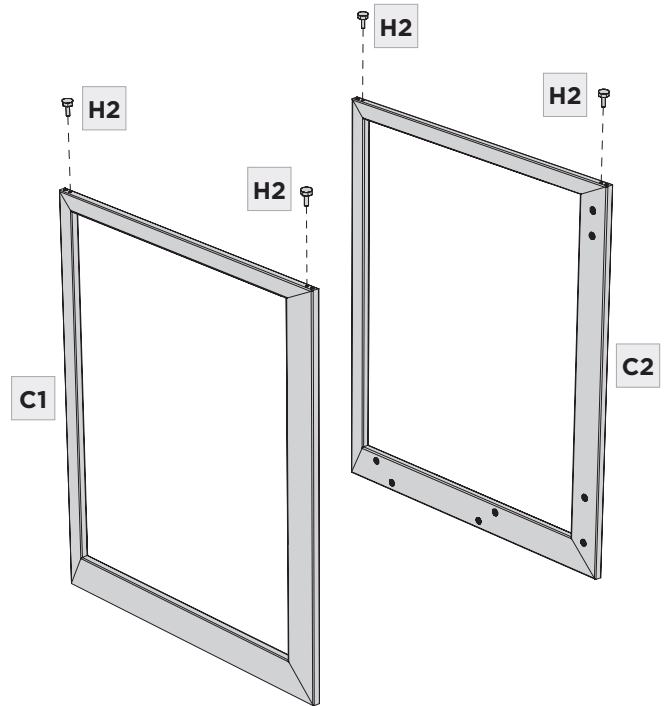

ASSEMBLY

STEP 2. INSTALL SCREWS (PARTIALLY)

With levelers down, **partially** install **(H1) Screws** into the **upper holes** of the paired inserts on the inside edges of **(C1) Left** and **(C2) Right Leg Frames**. **(H1) Screw** heads should be 1/4" (6mm) away from frame.

	PART/DESCRIPTION	QTY
	H1-SCREW	8

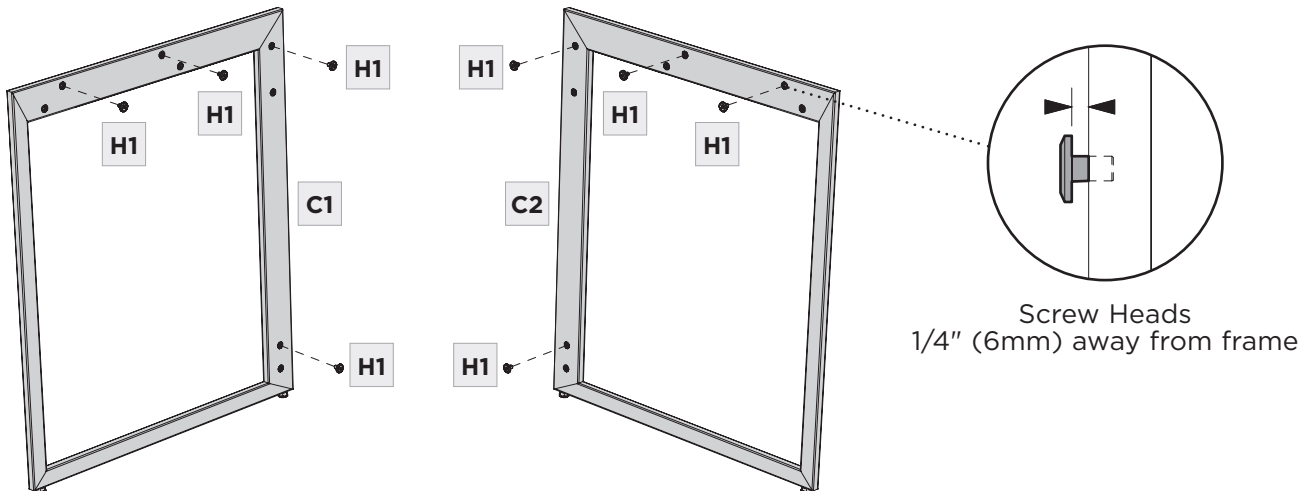

STEP 3. INSTALL DRAWER ASSEMBLY FRAME

ASSEMBLY

On a soft surface such as a carpet, position **(C2) Right Leg Frame** as shown and hook **(C3) Drawer Assembly Frame** onto the partially threaded screws on the top of **(C2) Right Leg Frame**. Slide the frame down so that the screws go into the keyhole slot.

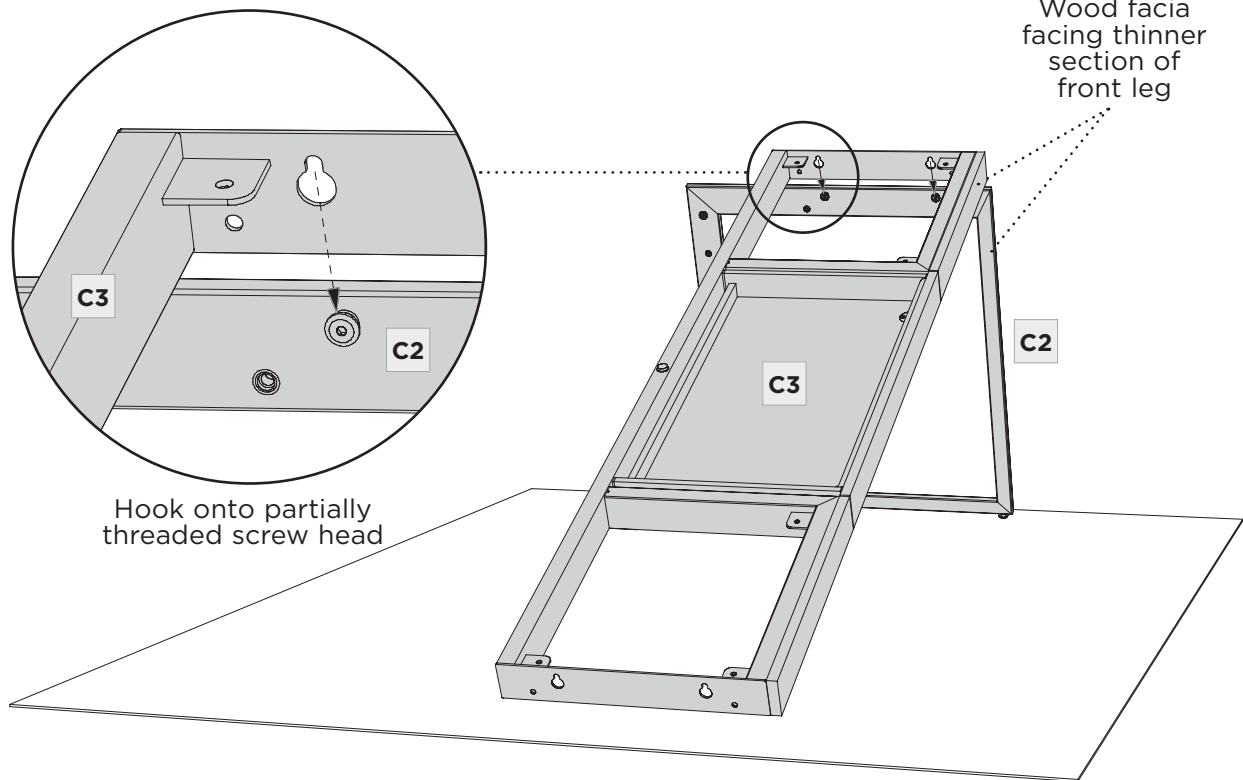

Insert **(H1) Screws** into the lower holes and **partially** tighten with **(T1) Hex Wrench**.

	PART/DESCRIPTION	QTY
	T1-HEX WRENCH	1
	H1-SCREW	2

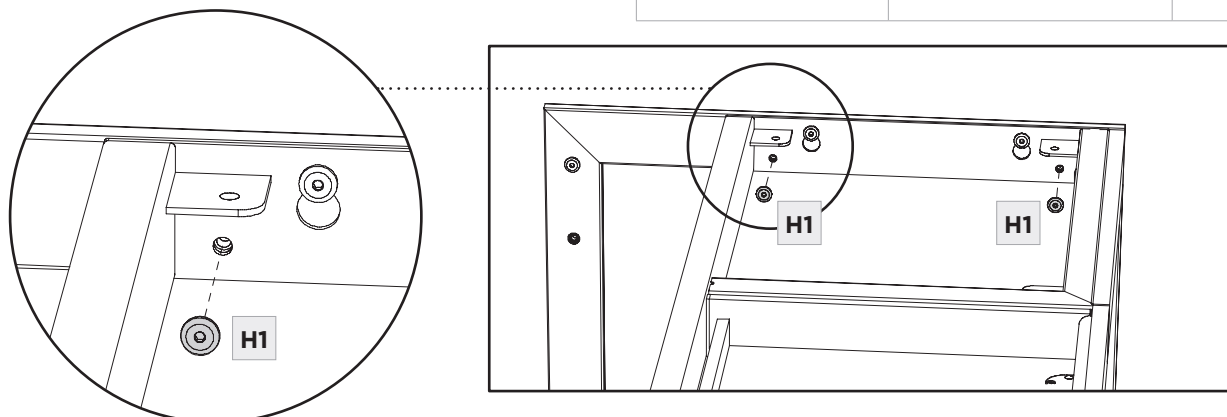

Lift and hook the **(C3) Drawer Assembly Frame** onto the 2 **partially** threaded screws at the top of **(C1) Left Leg Frame**. Insert **(H1) Screws** into the lower holes and **partially** tighten with **(T1) Hex Wrench**.

	PART/DESCRIPTION	QTY
	T1-HEX WRENCH	1
	H1-SCREW	2

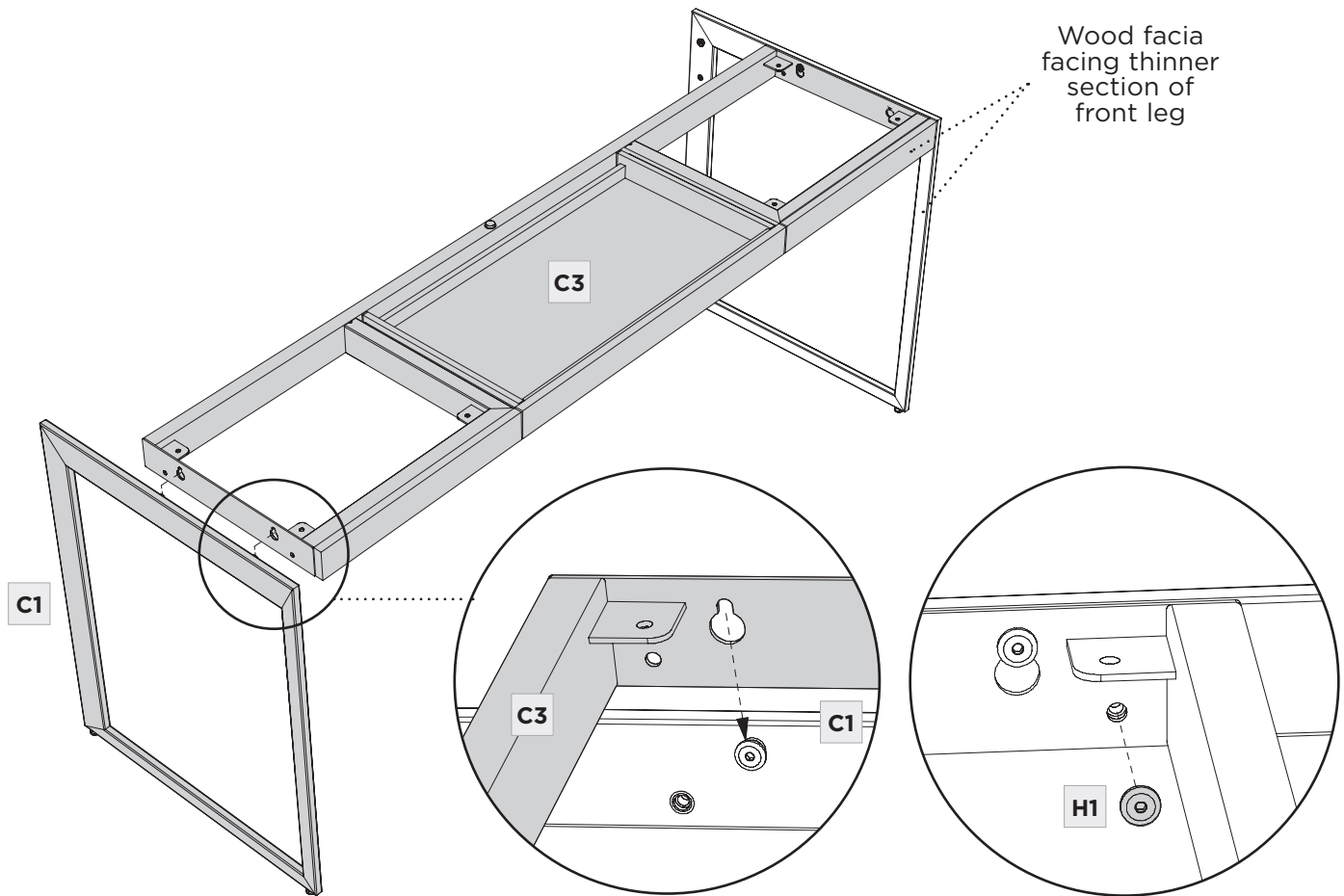

STEP 5. INSTALL LOWER HORIZONTAL FRAME

ASSEMBLY

Lift and hook the **(C4) Lower Horizontal Frame** onto the partially threaded screws as shown. Insert **(H1) Screws** into the lower holes and partially tighten with **(T1) Hex Wrench**.

	PART/DESCRIPTION	QTY
	T1-HEX WRENCH	1
	H1-SCREW	2

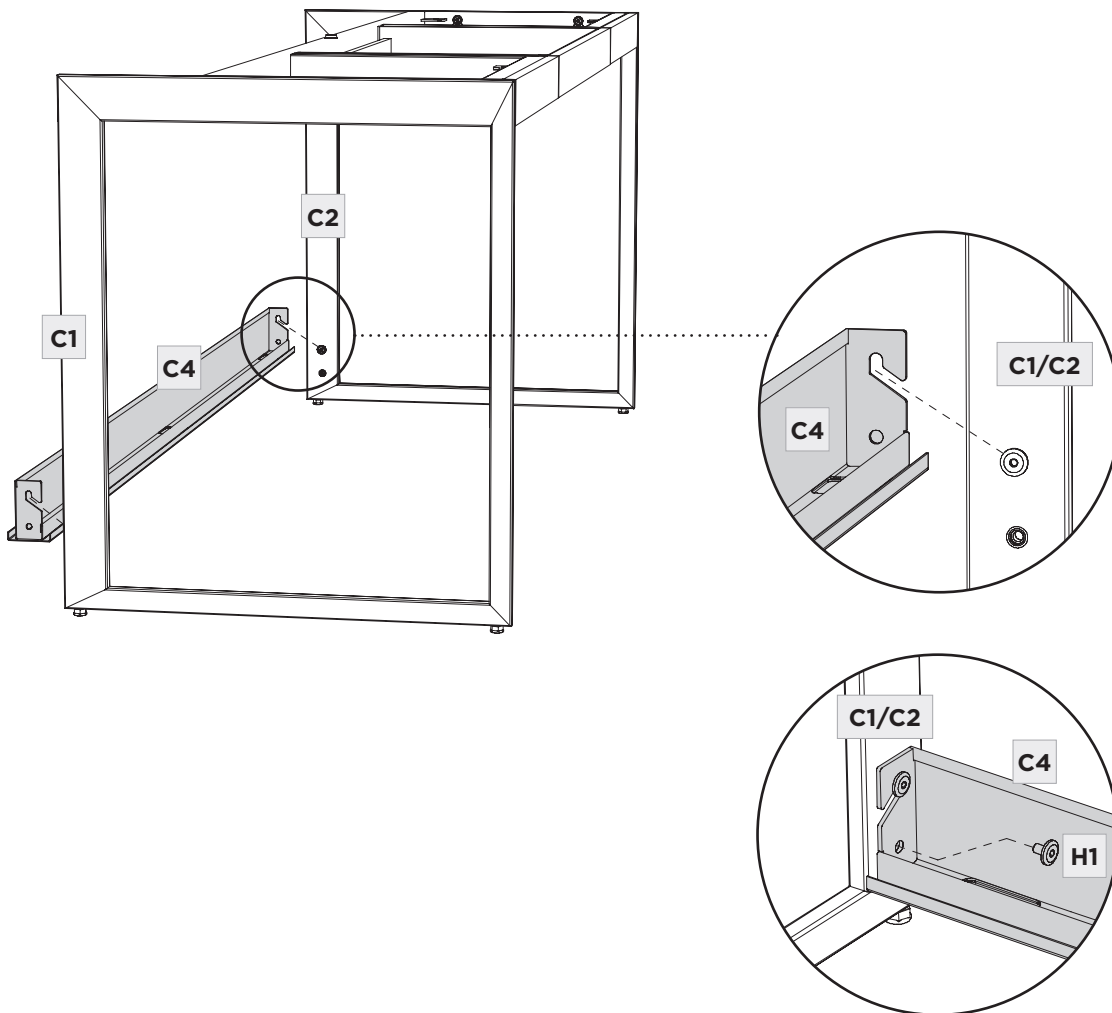

ASSEMBLY

STEP 6. INSTALL UPPER HORIZONTAL FRAME

Lift and hook the **(C5) Upper Horizontal Frame** onto the partially threaded screws as shown. Insert **(H1) Screws** into the lower holes and partially tighten with **(T1) Hex Wrench**.

Including previous steps, **fully tighten all screws!**

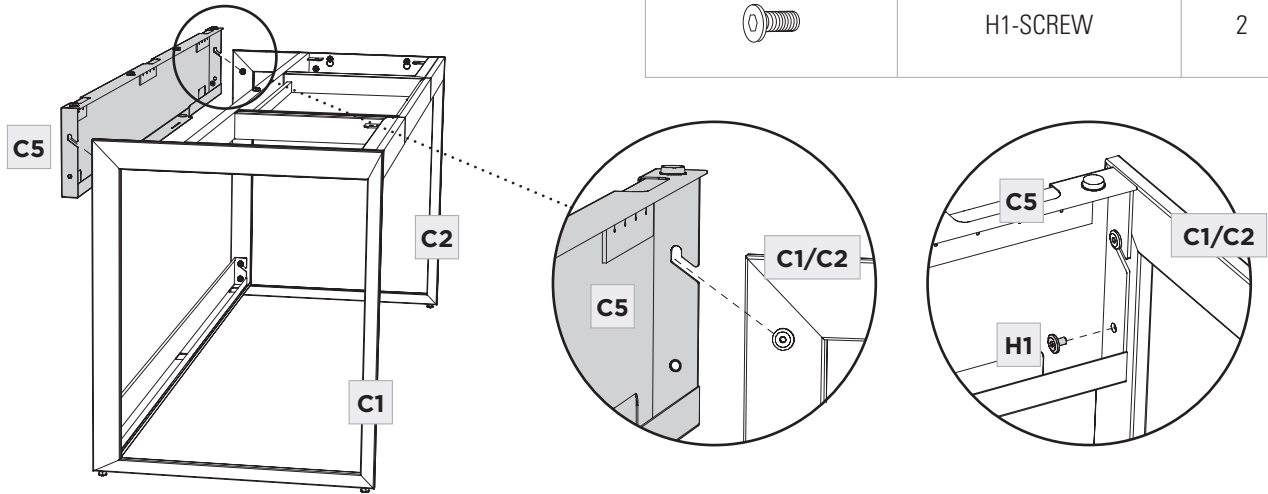

ASSEMBLY

STEP 7. INSTALL WIRE TRAY

Install the **(C6) Wire Tray** as shown by inserting the 2 metal tabs into the 2 slots on the **(C5) Upper Horizontal Frame**.

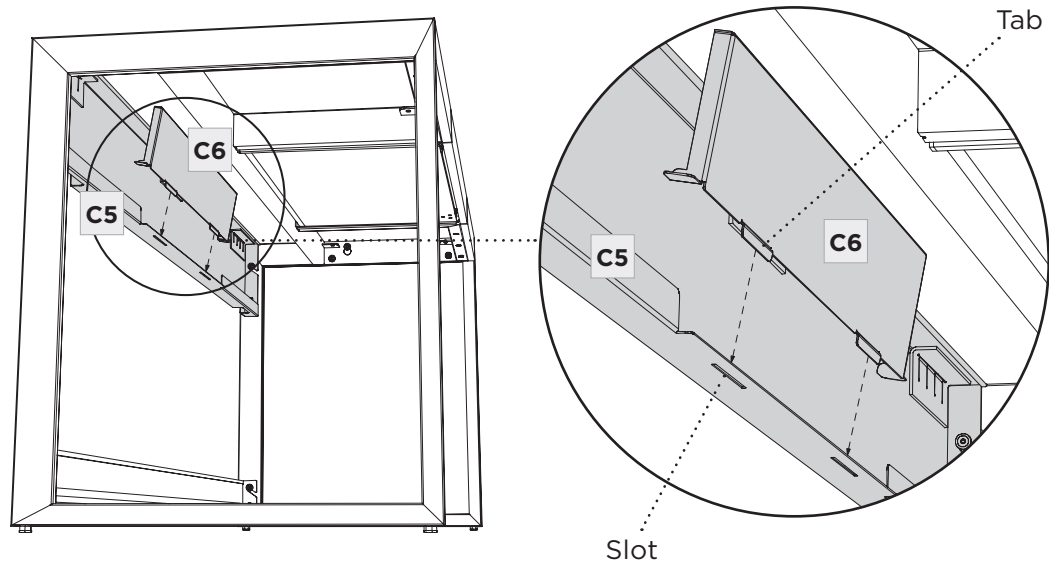

STEP 8. ROTATE WIRE TRAY

ASSEMBLY

Rotate the **(C6) Wire Tray** down as shown. Position the desk. The wire tray may be used to hold power strips, surge protectors, and power bricks (not provided).

Note: If positioning your desk in the middle of a room, power cords may be routed through the holes on the (C4) Lower Horizontal Frame.

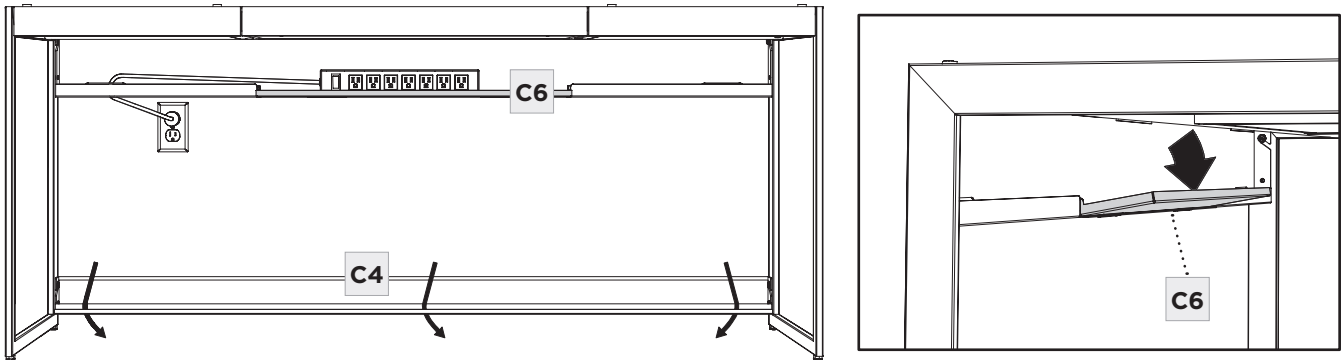

STEP 9. INSTALL BACK PANEL—OPTIONAL

ASSEMBLY

If positioning your desk away from a wall, the **(C7) Back Panel** may be installed. The lower edge goes into the channel on the **(C4) Lower Horizontal Frame** and is held in place with magnets.

Note: (C7) Back Panel is included with 6101 Large Desk, but is not included with 6103 Compact Desk. It must be ordered separately (6108).

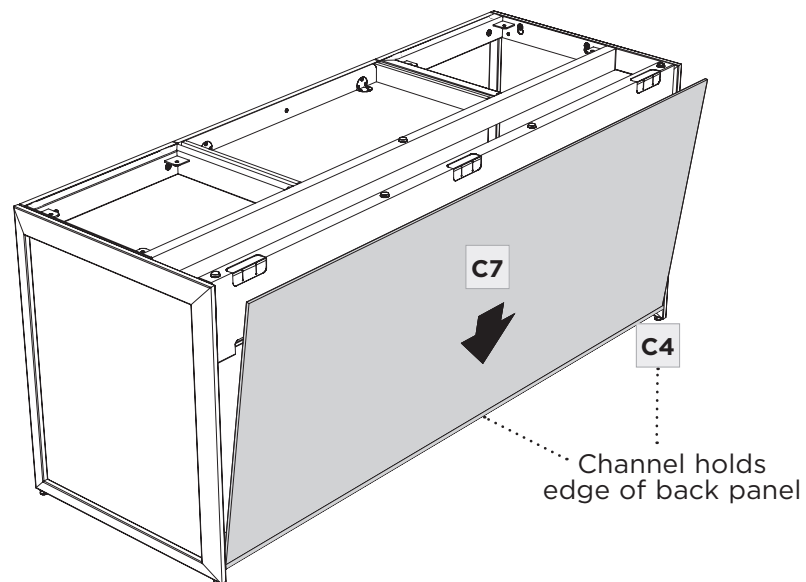

ASSEMBLY

STEP 10. INSTALL TOP PANEL

Install the **(C8) Top Panel** as shown and secure with **(H1) Screws** going through the metal tabs on the frame and into the inserts in the corners of the guide blocks under the **(C8) Top Panel**. Tighten using the **(T1) Hex Wrench**.

	PART/DESCRIPTION	QTY
	T1-HEX WRENCH	1
	H1-SCREW	6

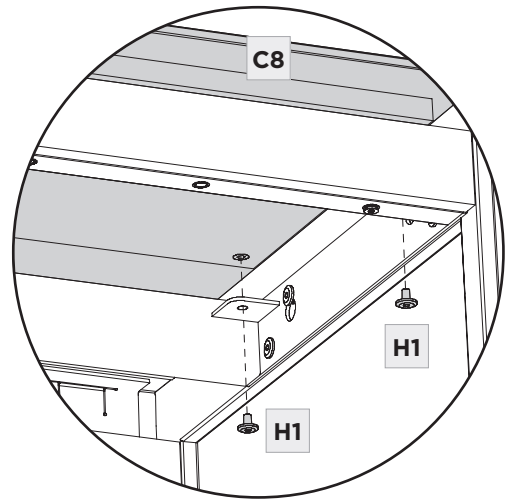
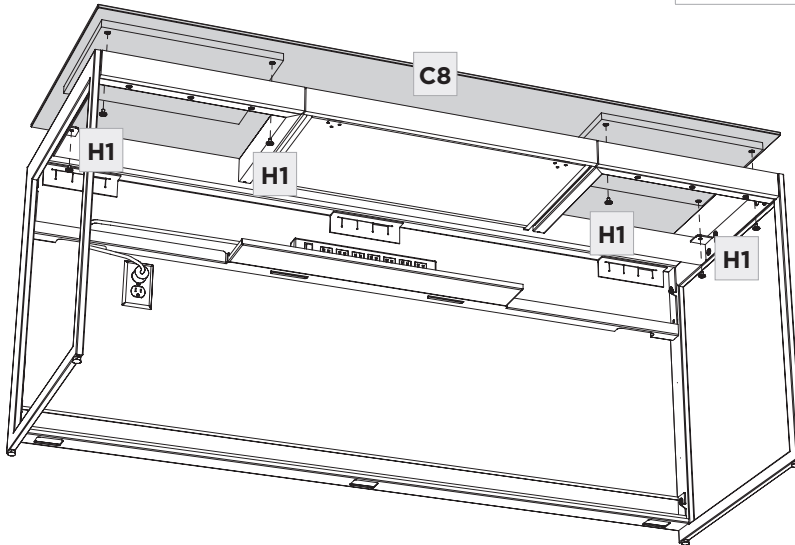

ASSEMBLY

STEP 11. INSTALL FRONT PANEL

Install the **(C9) Front Panel** by placing the bottom edge into the channel on the front of the **(C4) Lower Horizontal Frame**. Rotate back and vertically until the top edge magnetically attaches to the frame.

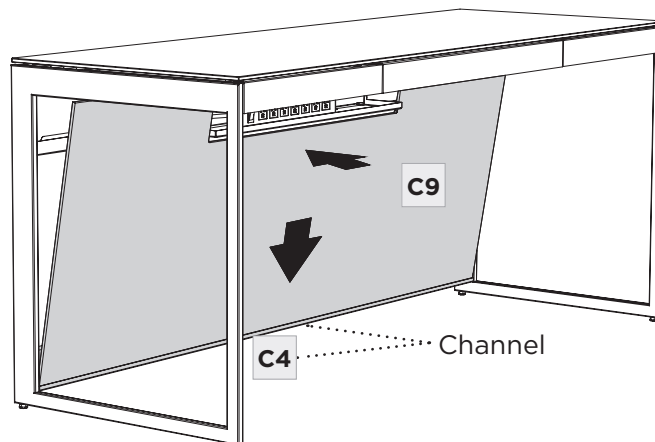

STEP 12. INSTALL DRAWER LINER

ASSEMBLY

Open drawer and install **(C10) Drawer Liner**.

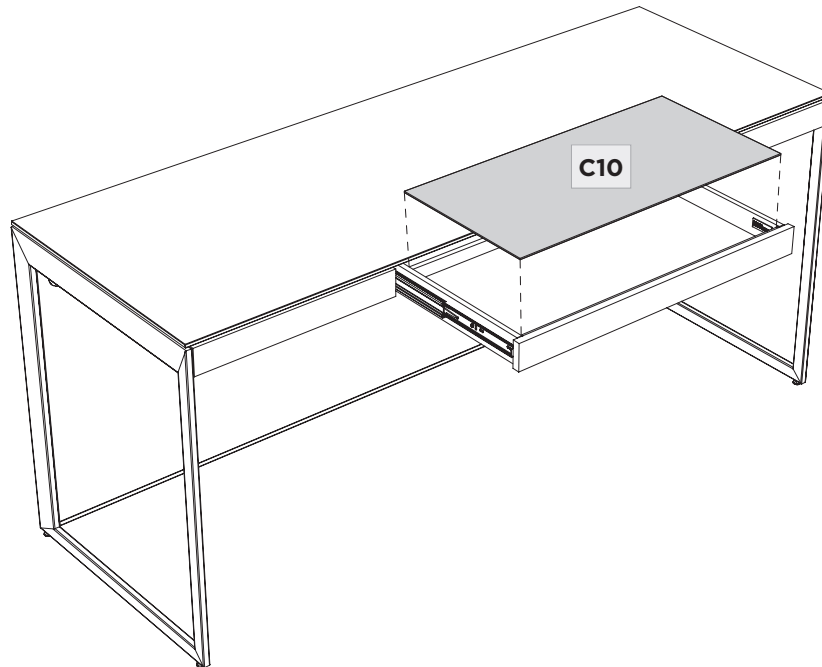

LEVEL DESK

FINE TUNING

If needed, dial out 1 or more of the levelers using **(T2) Leveler Wrench**.

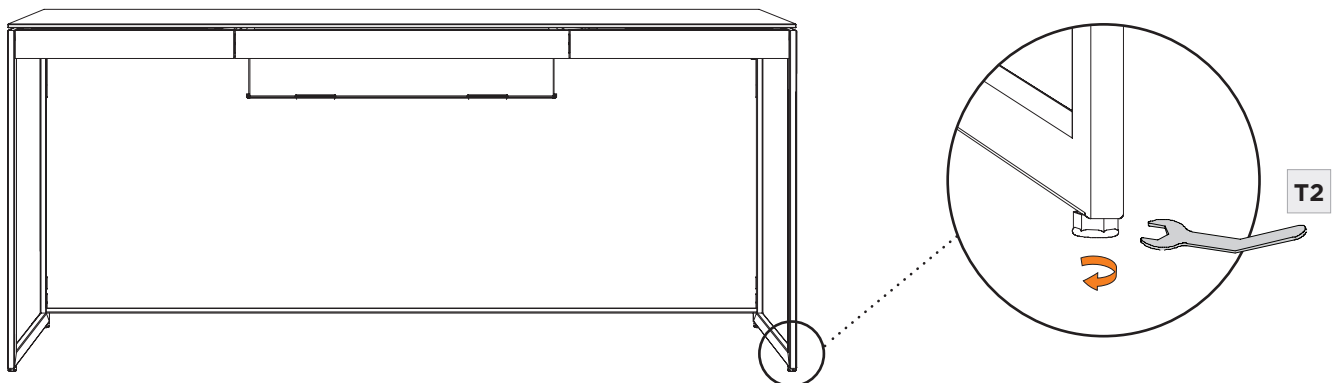

CARE & MAINTENANCE

GLASS

Glass surface is maintained using household glass cleaner and a paper towel or cloth.

SATIN-ETCHED GLASS

This uniquely smooth-to-the-touch glass surface can be regularly maintained using household glass cleaner and a paper towel or cloth. Minor scratches or scuffs not eliminated using paper towel or cloth can usually be removed by using a 'Magic Eraser'. Magic Eraser is a melamine foam product available at any grocery store or home improvement center. Dampen the entire glass surface as well as the Magic Eraser, then rub the entire glass surface in broad, even strokes using moderate pressure. Clean and dry the surface with a paper towel. Check for results and repeat as necessary.

Any scratches or scuffing not eliminated by one of the above methods can often be addressed by 'refreshing' the glass. This is a process that should not be required more than once per 6-12 months. See this brief video for the simple method: www.bdiusa.com/glass

WOOD

Wood surfaces should be cleaned with a slightly damp (not saturated) cloth or paper towel. Do not use glass cleaner on wood. If moisture remains, dry the surface with another cloth. If needed, a gentle non-abrasive cleanser may be used, but be sure to wipe away all cleaner residue and dry the surface with a cloth.

BDI's wood finishes feature natural hardwood solids and veneers. Wood is a product of nature and—unlike man-made materials that can be manufactured to strict and consistent specifications—has natural imperfections that are part of its appeal and character. Every piece of wood differs from every other, even when coming from the very same tree. As such, variation in grain, texture and tone should be expected from one panel or piece of furniture to the next.

While BDI's stained wood finishes are stable in tone & appearance, all finishes are subject to some degree of discoloration with prolonged exposure to direct sunlight. Please take care to avoid positioning your BDI cabinet in any area with extensive direct sunlight. To learn more about the features of natural wood, visit www.bdiusa.com/wood

METAL & PAINTED SURFACES

Surfaces should be cleaned with a slightly damp (not saturated) cloth or paper towel. If moisture remains, dry the surface with another cloth. If needed, a gentle non-abrasive cleanser may be used, but be sure to wipe away all cleaner residue and dry the surface with a cloth.

WARRANTY

BDI warrants to the original purchaser that for the below-stated warranty term, BDI will replace any product, part, or component covered by this warranty that fails under normal use as a result of a defect in material or workmanship. The decision to replace a complete product versus the part or component in question will be at BDI's sole discretion.

Residential Use: BDI Furnishings carry warranty coverage for three (3) years from the date of product delivery, as shown on your sales receipt/documentation. Select chairs carry coverage for five (5) years from the date of product delivery.

Commercial Use: BDI Furnishings carry warranty coverage for one (1) year from the date of product delivery, as shown on your sales receipt/documentation. Select chairs carry coverage for five (5) years from the date of the product delivery, based on an 8-hour daily use pattern.

BDI reserves the right to refine or update its warranty from time to time. See the complete and latest warranty document at www.bdiusa.com/warranty.

PRODUCT REGISTRATION

Registering your new BDI product allows us to send you important product updates, service information and helpful hints related to your BDI products. Register today, and you will be entered to win free a BINK table from BDI: www.bdiusa.com/register



WARNING

SERIOUS OR FATAL CRUSHING INJURIES CAN OCCUR FROM FURNITURE TIP-OVER. TO HELP PREVENT TIP-OVER:

- Install tip-over restraint.
- Place heaviest items in lower compartments.
- Never allow children to climb or hang on drawers, doors or shelves.
- Never open more than one drawer at a time.

USE OF TIP-OVER RESTRAINT MAY REDUCE—BUT NOT ELIMINATE—THE RISK OF TIP-OVER.



These distinctive product configurations are protected by US and international patents, trade dress, and/or copyright laws. Sequel & BDI are trademarks of Becker Designed, Inc. All rights reserved. ©2020, BDI | V.08.21.2020

Made in Vietnam.

SEQUEL[®] 20 6112

RETURN

INSTRUCTION MANUAL

LET'S GET STARTED.

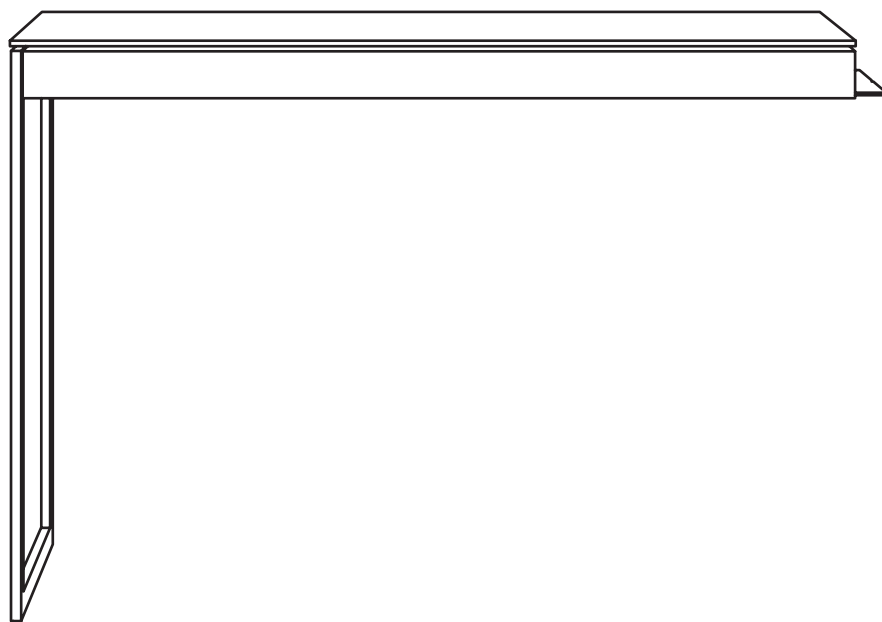

DESIGN MATTHEW WEATHERLY

BDi

BDIUSA.COM



Congratulations on the purchase of your Sequel 20 Return 6112 from BDI. Your return has been designed to provide a lifetime of enjoyment. This manual will provide you with assembly instructions and other helpful information that will ensure that you get the most out of your return. Please save it for future reference.

Your Sequel 20 Return has been engineered for simple assembly. Please follow these directions carefully to prevent any damage.

Should you need further assistance, contact BDI at customerservice@bdiusa.com.

ENJOY!

HARDWARE AND COMPONENTS

Unpack and identify the parts listed below. The assembly workspace should be a non-marring surface such as carpet. For missing hardware pieces, please contact BDI Customer Service at customerservice@bdiusa.com.

Do not use power tools for assembly of this product.

For all other concerns, please contact your BDI retailer.



PART #	T1
DESCRIPTION	Hex Wrench
QUANTITY	1

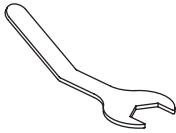

PART #	T2
DESCRIPTION	Hex Wrench
QUANTITY	1

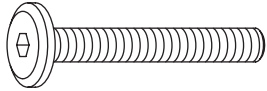

PART #	H1
DESCRIPTION	M6 x 40mm Screw
QUANTITY	4

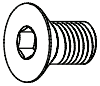

PART #	H2
DESCRIPTION	M6 x 10mm Flathead Screw
QUANTITY	4

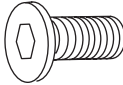

PART #	H3
DESCRIPTION	M6 x 15mm Screw
QUANTITY	5



PART #	H4
DESCRIPTION	Leveler
QUANTITY	2

HARDWARE AND COMPONENTS

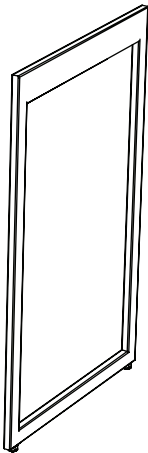

PART #	C1
DESCRIPTION	Leg Frame
QUANTITY	1

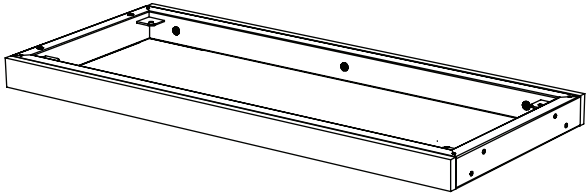

PART #	C2
DESCRIPTION	Top Frame
QUANTITY	1

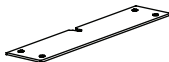

PART #	C3
DESCRIPTION	Connector Plate
QUANTITY	1

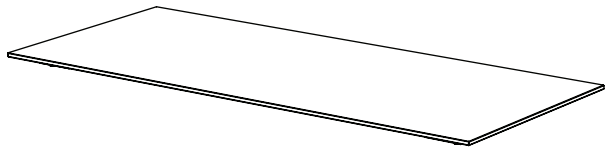

PART #	C4
DESCRIPTION	Top Panel
QUANTITY	1

ASSEMBLY**STEP 1. INSTALL LEVELERS**

Install **(H4) Levelers** into the bottom of **(C1) Leg Frame**.

	PART/DESCRIPTION	QTY
	H4-LEVELER	2

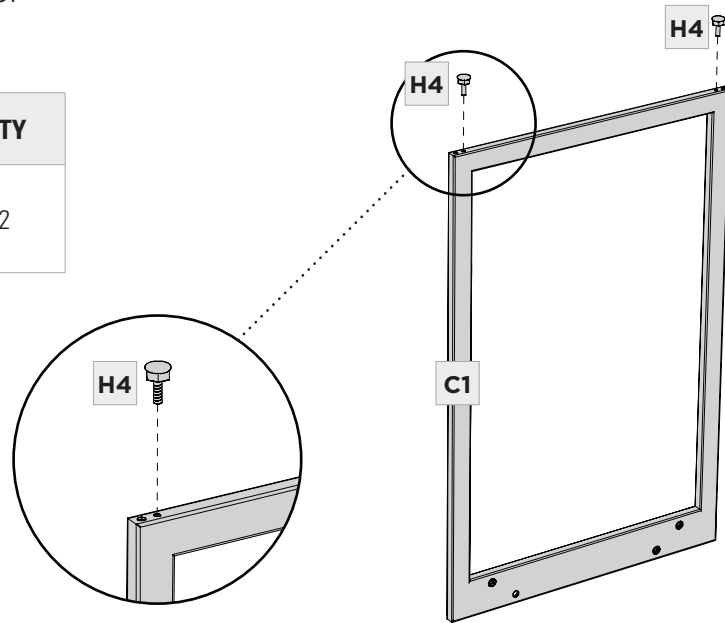
**ASSEMBLY****STEP 2. INSTALL TOP FRAME**

Connect **(C1) Leg Frame** to **(C2) Top Frame** using **4 (H1) Screws** and tighten with **(T1) Hex Wrench**.

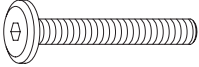
	PART/DESCRIPTION	QTY
	T1-HEX WRENCH	1
	H1-SCREW	4

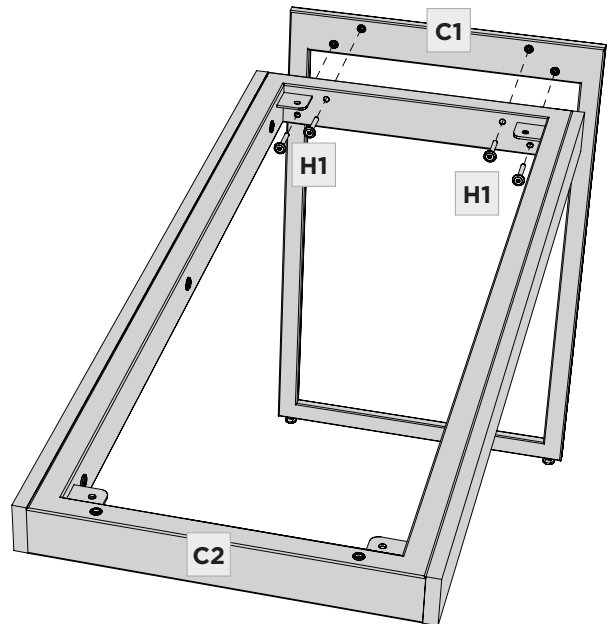



STEP 3. INSTALL CONNECTOR PLATE

ASSEMBLY

The return may be attached to either a desk or a cabinet.

IF ATTACHING TO A DESK—
COMPATIBLE WITH 6101, 6102:

Connect the **(C3) Connector Plate** to the underside of **(C2) Top Frame** using **2 (H2) Flathead Screws** and **(T1) Hex Wrench**. Make sure notch is facing outward. **Go to step 4.**

	PART/DESCRIPTION	QTY
	T1-HEX WRENCH	1
	H2-FLATHEAD SCREW	2

IF ATTACHING TO A CABINET—
COMPATIBLE WITH 6114, 6116, 6117:

Connect the **(C3) Connector Plate** to the topside of **(C2) Top Frame** using **2 (H2) Flathead Screws**. Make sure notch is facing outward. **Go to step 8.**

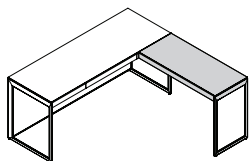

Connecting to desk
plate goes on bottom

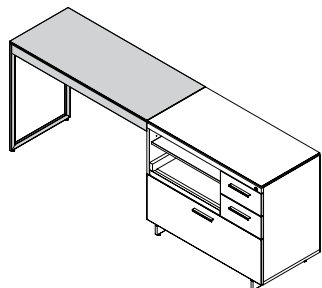

Connecting to cabinet
plate goes on the top

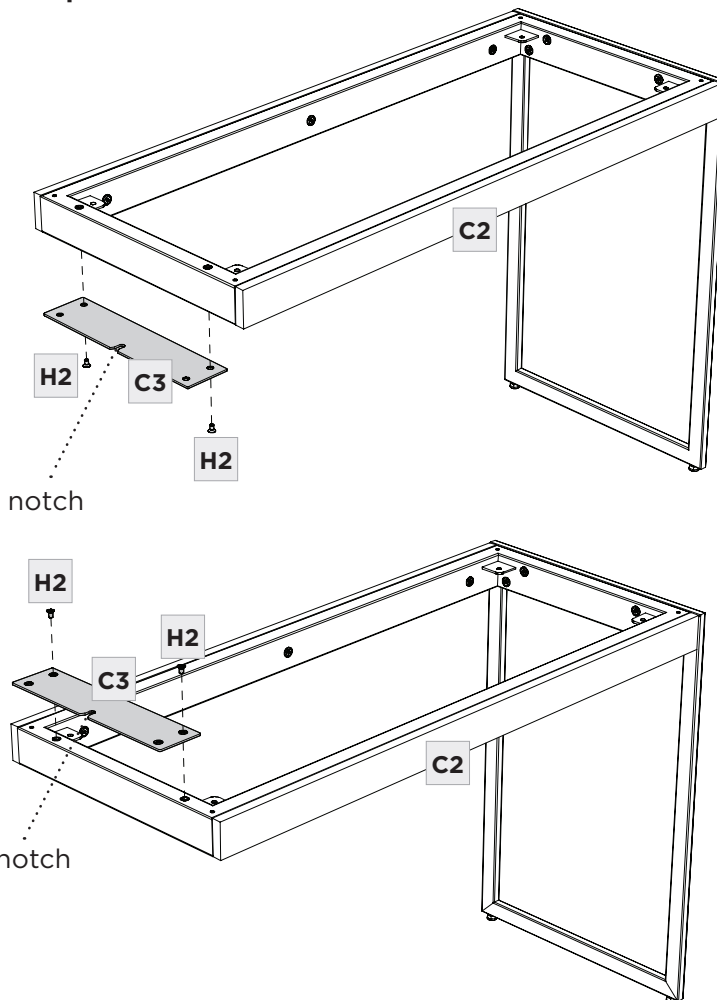

The return may be attached either to the **left** or **right** of the center drawer (**right side shown below**). Partially thread **1 (H3) Screw** into the **middle insert** leaving it extended out **1/4" (6mm)** to allow **(C3) Connector Plate** to slide into the space between the screw head and bottom of the desk.

	PART/DESCRIPTION	QTY
	H3-SCREW	1

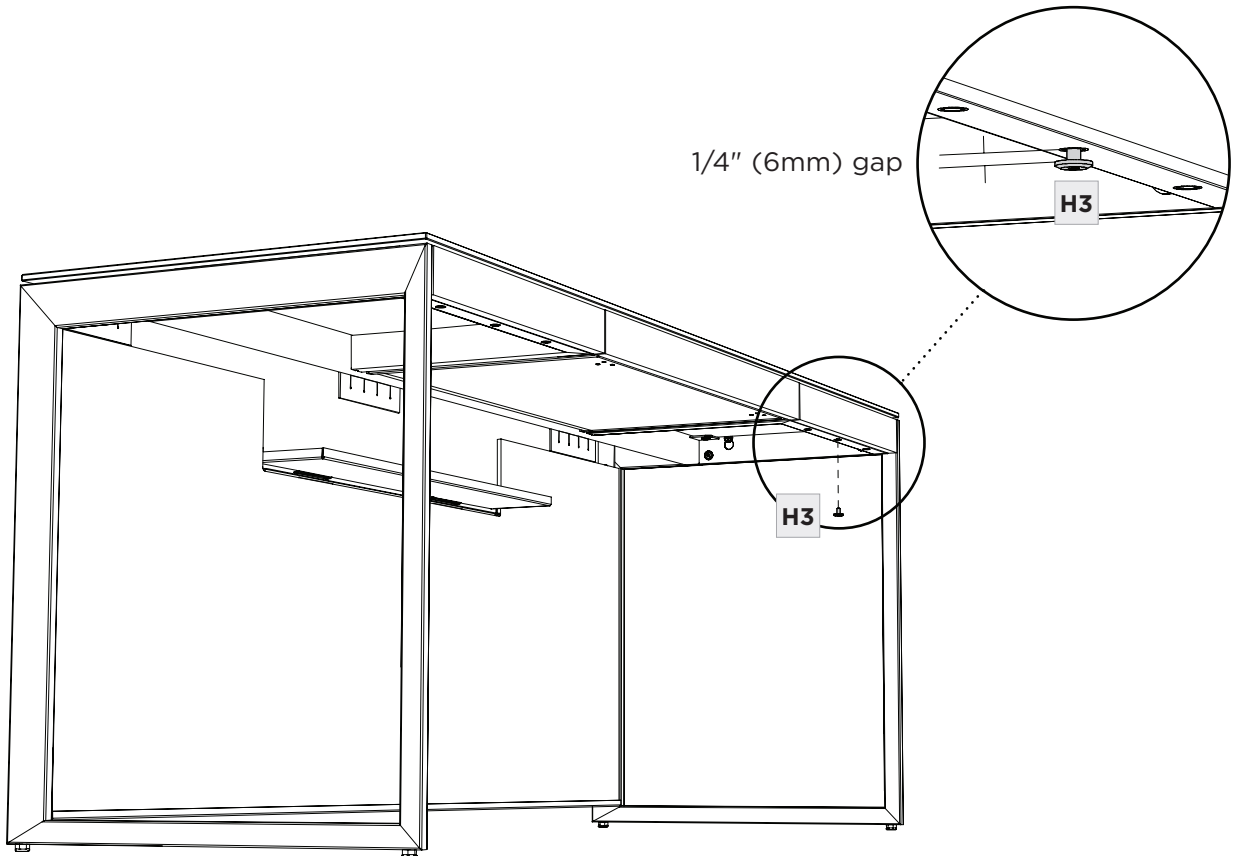

STEP 5. ATTACH THE RETURN

ASSEMBLY

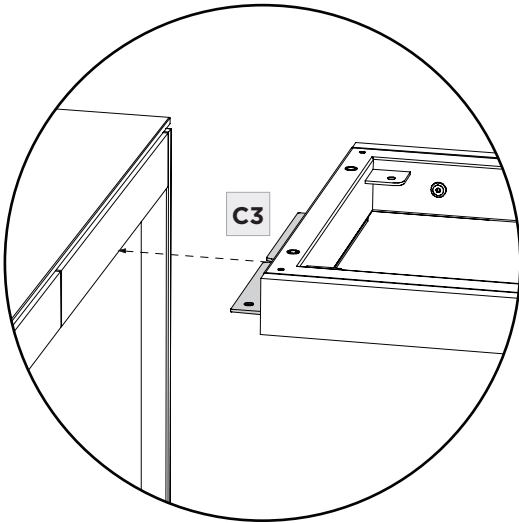

Slide the notch on **(C3) Connector Plate** onto the partially threaded **middle screw**. Tighten the screw with **(T1) Hex Wrench**.



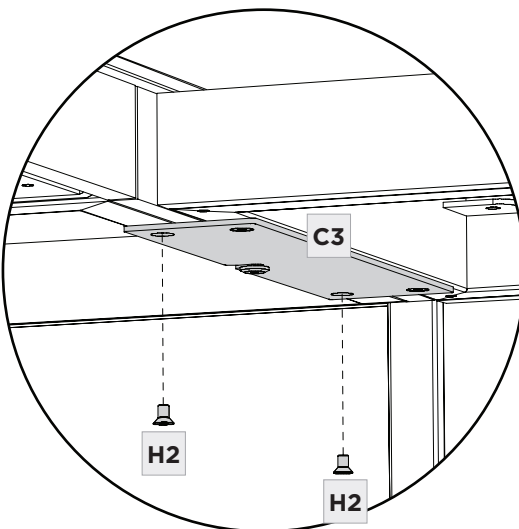

	PART/DESCRIPTION	QTY
	T1-HEX WRENCH	1

Insert **(H2) Flathead Screws** into the left and right holes on the **(C3) Connector Plate** and tighten with **(T1) Hex Wrench**.



	PART/DESCRIPTION	QTY
	T1-HEX WRENCH	1
	H2-FLATHEAD SCREW	2

Attach **(C4) Top Panel** by placing it on top of the return and fastening with **(H3) Screws** going through the metal tabs in the corners and into the inserts on the underside of the **(C4) Top Panel**. Make sure the gap between desk glass and return glass is even, then tighten with **(T1) Hex Wrench**.

	PART/DESCRIPTION	QTY
	T1-HEX WRENCH	1
	H3-SCREW	4

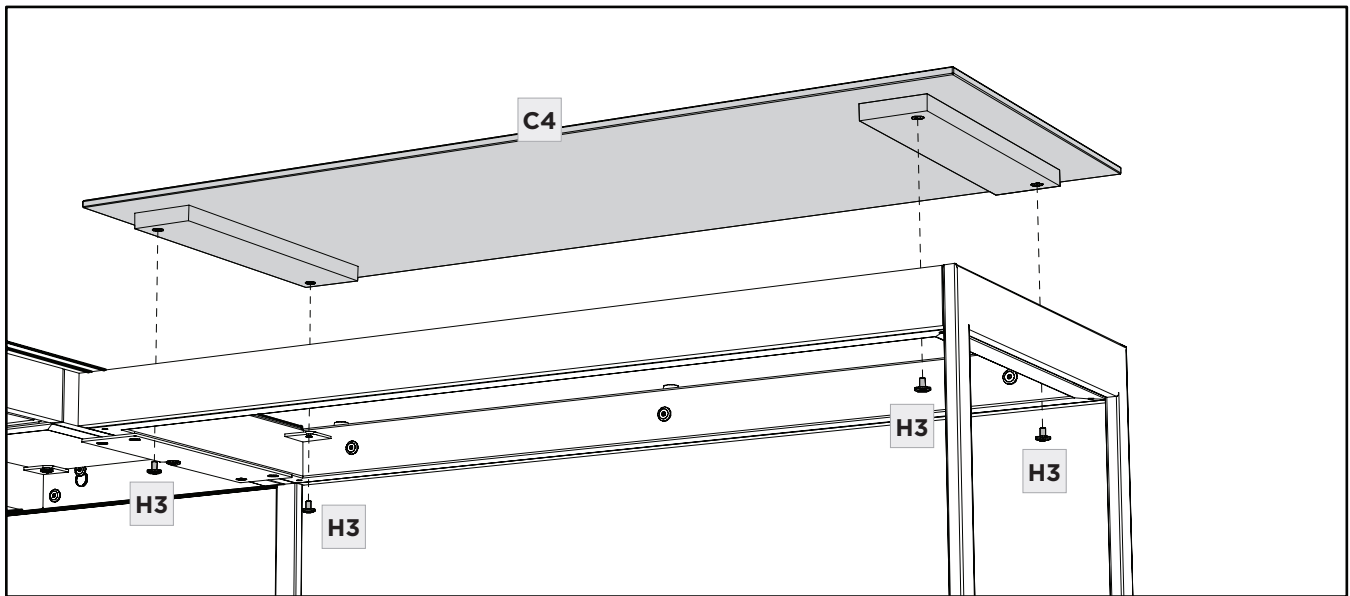



STEP 7. INSTALL TOP PANEL

ASSEMBLY

The return may be attached to the left or right side of the following cabinets:



- 6114 3 Drawer File Pedestal
- 6116 Lateral File
- 6117 Multi-Function Cabinet—shown below

First, remove the glass top from the cabinet. Attach the **(C3) Connector Plate** to the cabinet using **(H2) Flathead Screws** going through the **(C3) Connector Plate** and into the 2 threaded holes on the top of the cabinet. Tighten with **(T1) Hex Wrench**. Re-install the glass top onto the cabinet.

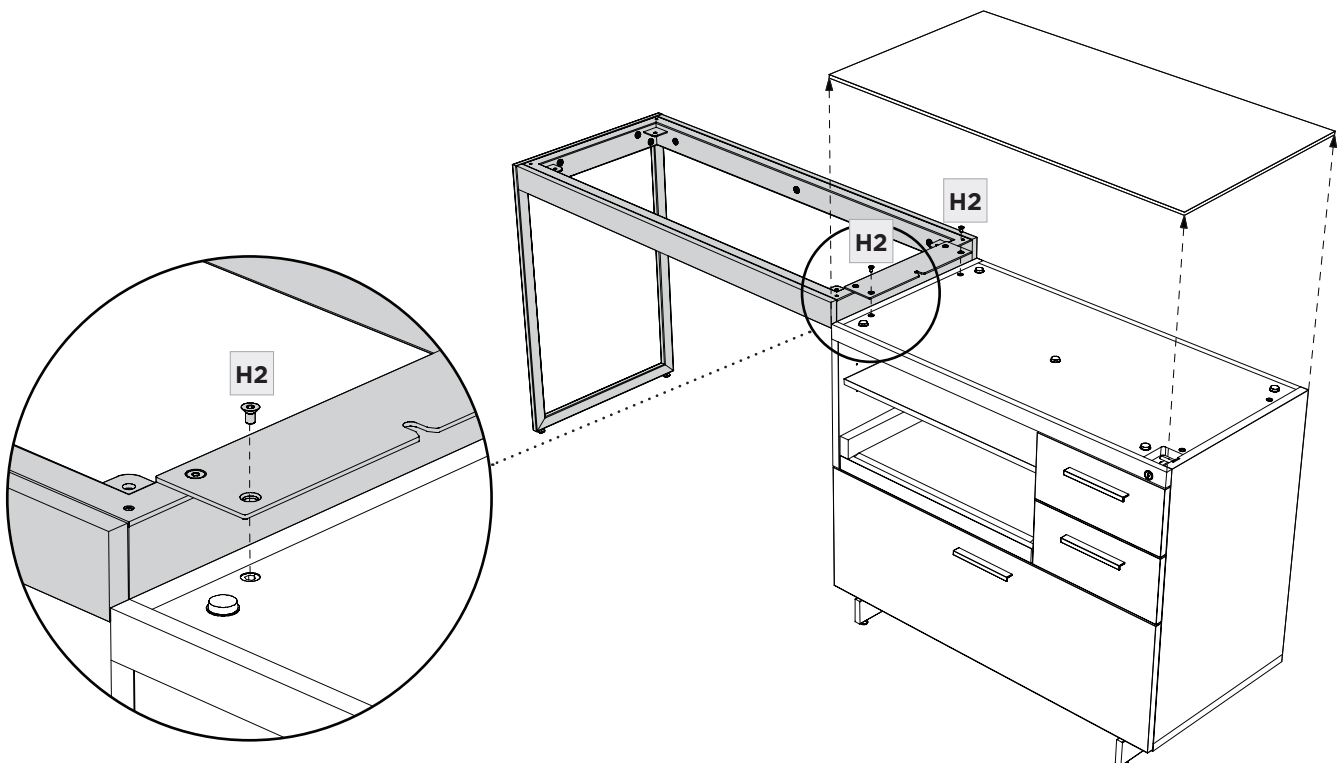
	PART/DESCRIPTION	QTY
	T1-HEX WRENCH	1
	H2-FLATHEAD SCREW	2



Attach **(C4) Top Panel** by placing it on top of the return and fastening with **(H3) Screws** going through the metal tabs in the corners and into the inserts on the underside of the **(C4) Top Panel**. Make sure the gap between desk glass and return glass is even, then tighten with **(T1) Hex Wrench**.

	PART/DESCRIPTION	QTY
	T1-HEX WRENCH	1
	H3-SCREW	4

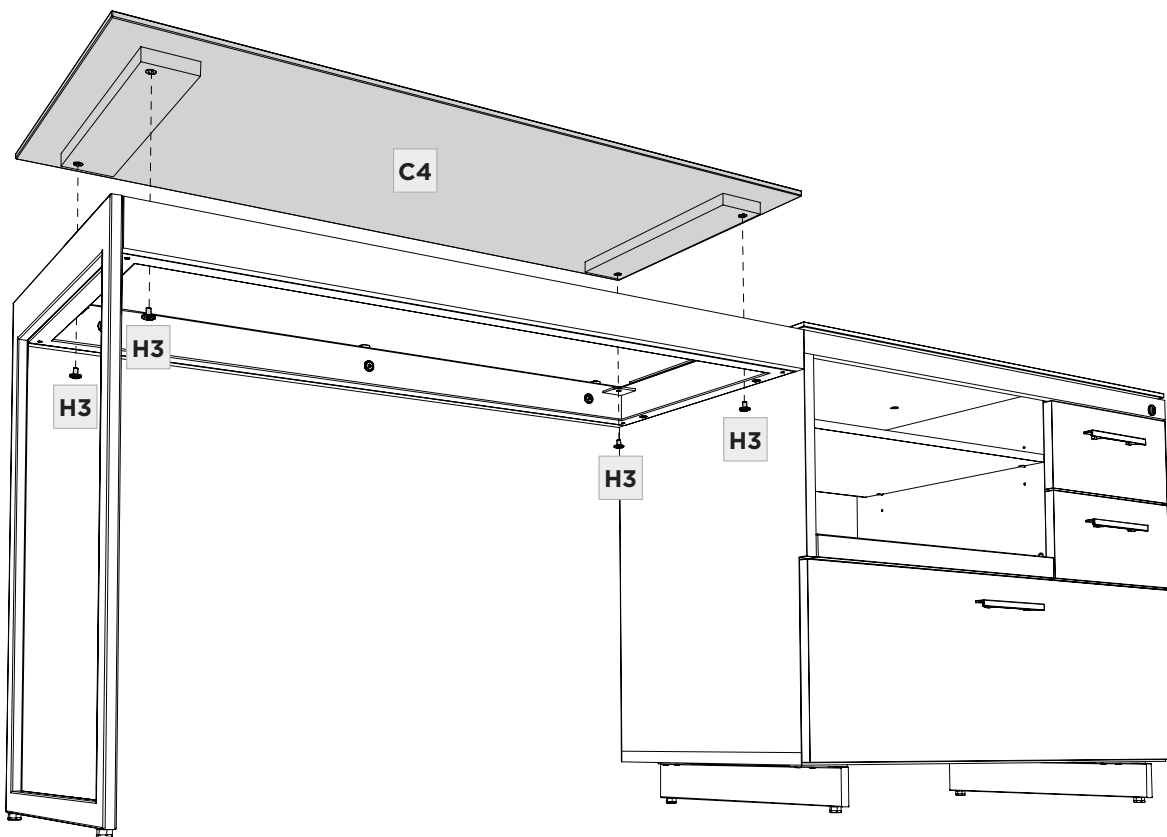

GLASS

Glass surface is maintained using household glass cleaner and a paper towel or cloth.

SATIN-ETCHED GLASS

This uniquely smooth-to-the-touch glass surface can be regularly maintained using household glass cleaner and a paper towel or cloth. Minor scratches or scuffs not eliminated using paper towel or cloth can usually be removed by using a 'Magic Eraser'. Magic Eraser is a melamine foam product available at any grocery store or home improvement center. Dampen the entire glass surface as well as the Magic Eraser, then rub the entire glass surface in broad, even strokes using moderate pressure. Clean and dry the surface with a paper towel. Check for results and repeat as necessary.

Any scratches or scuffing not eliminated by one of the above methods can often be addressed by 'refreshing' the glass. This is a process that should not be required more than once per 6-12 months. See this brief video for the simple method: www.bdiusa.com/glass

WOOD

Wood surfaces should be cleaned with a slightly damp (not saturated) cloth or paper towel. Do not use glass cleaner on wood. If moisture remains, dry the surface with another cloth. If needed, a gentle non-abrasive cleanser may be used, but be sure to wipe away all cleaner residue and dry the surface with a cloth.

BDI's wood finishes feature natural hardwood solids and veneers. Wood is a product of nature and—unlike man-made materials that can be manufactured to strict and consistent specifications—has natural imperfections that are part of its appeal and character. Every piece of wood differs from every other, even when coming from the very same tree. As such, variation in grain, texture and tone should be expected from one panel or piece of furniture to the next.

While BDI's stained wood finishes are stable in tone & appearance, all finishes are subject to some degree of discoloration with prolonged exposure to direct sunlight. Please take care to avoid positioning your BDI cabinet in any area with extensive direct sunlight. To learn more about the features of natural wood, visit www.bdiusa.com/wood

METAL & PAINTED SURFACES

Surfaces should be cleaned with a slightly damp (not saturated) cloth or paper towel. If moisture remains, dry the surface with another cloth. If needed, a gentle non-abrasive cleanser may be used, but be sure to wipe away all cleaner residue and dry the surface with a cloth.

WARRANTY

BDI warrants to the original purchaser that for the below-stated warranty term, BDI will replace any product, part, or component covered by this warranty that fails under normal use as a result of a defect in material or workmanship. The decision to replace a complete product versus the part or component in question will be at BDI's sole discretion.

Residential Use: BDI Furnishings carry warranty coverage for three (3) years from the date of product delivery, as shown on your sales receipt/documentation. Select chairs carry coverage for five (5) years from the date of product delivery.

Commercial Use: BDI Furnishings carry warranty coverage for one (1) year from the date of product delivery, as shown on your sales receipt/documentation. Select chairs carry coverage for five (5) years from the date of the product delivery, based on an 8-hour daily use pattern.

BDI reserves the right to refine or update its warranty from time to time. See the complete and latest warranty document at www.bdiusa.com/warranty.

PRODUCT REGISTRATION

Registering your new BDI product allows us to send you important product updates, service information and helpful hints related to your BDI products. Register today, and you will be entered to win free a BINK table from BDI: www.bdiusa.com/register



WARNING

SERIOUS OR FATAL CRUSHING INJURIES CAN OCCUR FROM FURNITURE TIP-OVER. TO HELP PREVENT TIP-OVER:

- Install tip-over restraint.
- Place heaviest items in lower compartments.
- Never allow children to climb or hang on drawers, doors or shelves.
- Never open more than one drawer at a time.

USE OF TIP-OVER RESTRAINT MAY REDUCE—BUT NOT ELIMINATE—THE RISK OF TIP-OVER.



These distinctive product configurations are protected by US and international patents, trade dress, and/or copyright laws. Sequel & BDI are trademarks of Becker Designed, Inc. All rights reserved. ©2020, BDI | V.08.21.2020

Made in Vietnam.