

# Harpe, the sound of *light*

design Christian Lava  
terzani.com

**TERZANI**  
LA LUCE PENSATA



**Name**  
Harpe  
single pendant

**Materials**  
metal

### Finishes | Code

-  matte pearl  
OW011S E8 B5 T
-  matte black nickel  
OW011S E8 B6 T
-  matte red gold  
OW011S E8 B8 T

### Body

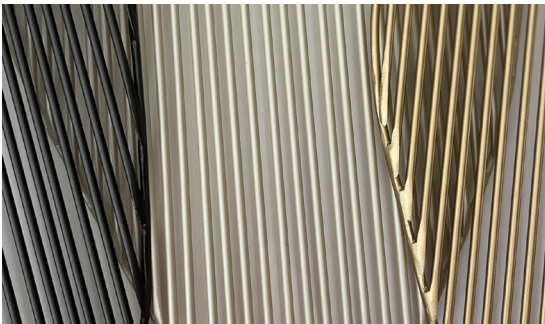
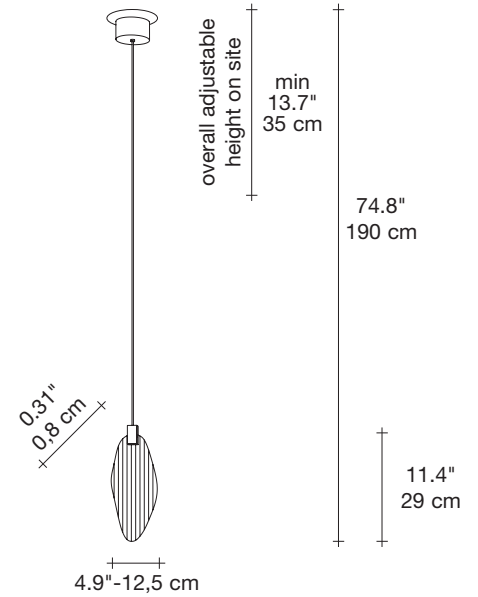

### Light source

700mA

-  Integrated LED  
2,1W 237 lm 3000K

dimmmable drivers available

-  IGBT / TRIAC

### Canopy | white

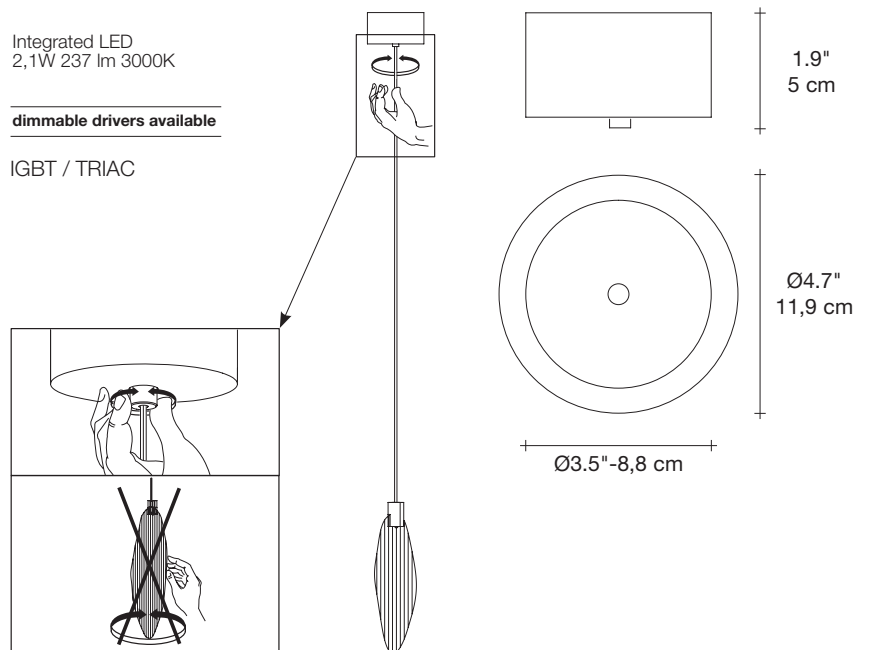

The new Harpe collection comes from the childhood memory of its designer, Christian Lava. Like most children, he would look up into the sky and visualize shapes in the clouds as they passed by. His active imagination would run wild with the fantastic things that emerged. One day, Christian looked up into the sky only to see a gray, leaden blanket of clouds. However, against this blank canvas, a break in the sky appeared, and bright sunlight came streaming down in rays reminiscent of a harp. It's the memory of this divine instrument that inspired our latest pendant, Harpe. Made of metal, Harpe is available in three different shapes and sizes, and can be assembled in infinite combinations. Design Christian Lava.

# Harpe, the sound of *light*

design Christian Lava  
terzani.com

**TERZANI**  
LA LUCE PENSATA



**Name**  
Harpe  
single pendant

**Materials**  
metal

### Finishes | Code

-  matte pearl  
OW012S E8 B5 T
-  matte black nickel  
OW012S E8 B6 T
-  matte red gold  
OW012S E8 B8 T

### Body

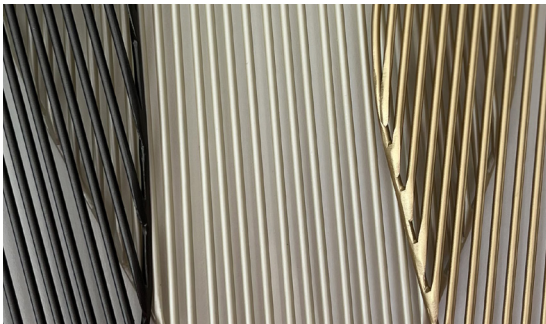
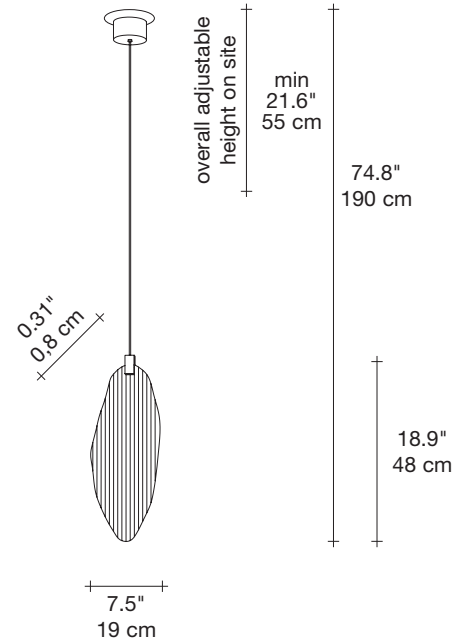

**Light source**  
700mA

-  Integrated LED  
2,1W 237 lm 3000K

dimmmable drivers available

-  IGBT / TRIAC

### Canopy | white

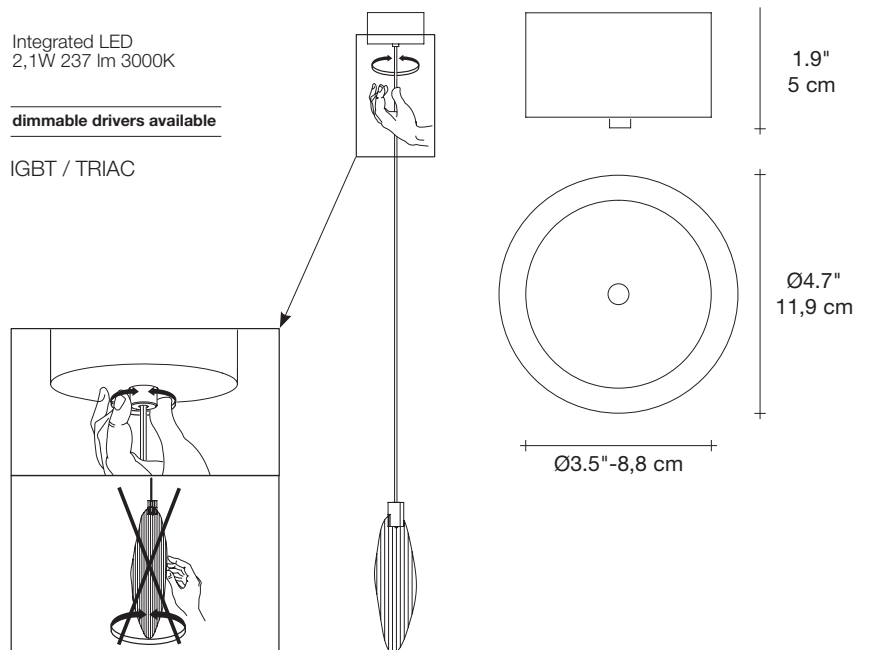

The new Harpe collection comes from the childhood memory of its designer, Christian Lava. Like most children, he would look up into the sky and visualize shapes in the clouds as they passed by. His active imagination would run wild with the fantastic things that emerged. One day, Christian looked up into the sky only to see a gray, leaden blanket of clouds. However, against this blank canvas, a break in the sky appeared, and bright sunlight came streaming down in rays reminiscent of a harp. It's the memory of this divine instrument that inspired our latest pendant, Harpe. Made of metal, Harpe is available in three different shapes and sizes, and can be assembled in infinite combinations. Design Christian Lava.

# Harpe, the sound of *light*

design Christian Lava  
terzani.com

**TERZANI**  
LA LUCE PENSATA



**Name**  
Harpe  
single pendant

**Materials**  
metal

### Finishes | Code

-  matte pearl  
OW013S E8 B5 T
-  matte black nickel  
OW013S E8 B6 T
-  matte red gold  
OW013S E8 B8 T

### Body

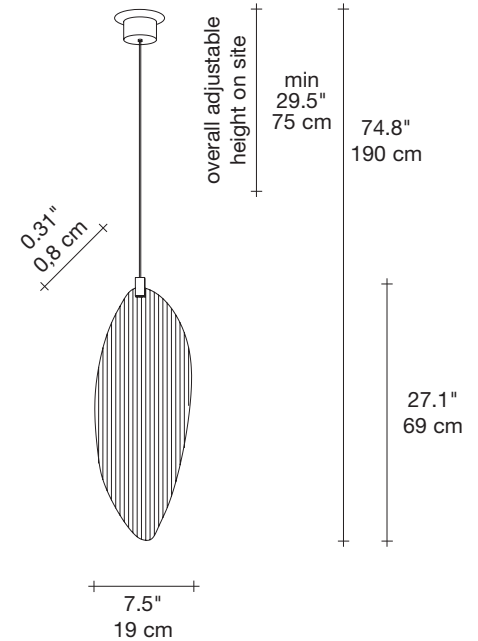

**Light source**  
700mA

-  Integrated LED  
2,1W 237 lm 3000K

dimmmable drivers available

-  IGBT / TRIAC

### Canopy | white

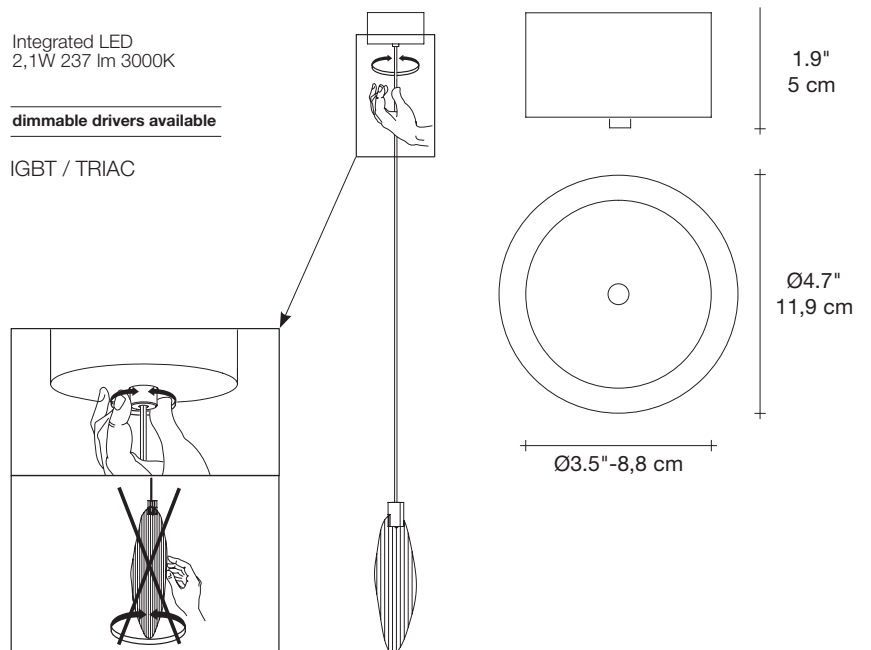

The new Harpe collection comes from the childhood memory of its designer, Christian Lava. Like most children, he would look up into the sky and visualize shapes in the clouds as they passed by. His active imagination would run wild with the fantastic things that emerged. One day, Christian looked up into the sky only to see a gray, leaden blanket of clouds. However, against this blank canvas, a break in the sky appeared, and bright sunlight came streaming down in rays reminiscent of a harp. It's the memory of this divine instrument that inspired our latest pendant, Harpe. Made of metal, Harpe is available in three different shapes and sizes, and can be assembled in infinite combinations. Design Christian Lava.