

SEQUEL[®] 20 6107

MOBILE FILE PEDESTAL

INSTRUCTION MANUAL

LET'S GET STARTED.

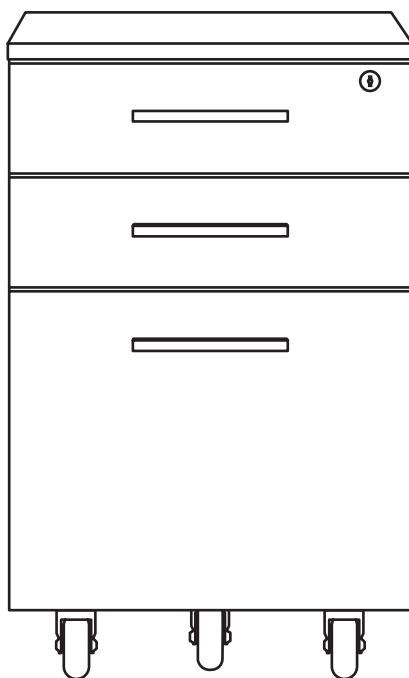

DESIGN MATTHEW WEATHERLY

BDi

BDIUSA.COM



Congratulations on the purchase of your Sequel 20 Mobile File Pedestal 6107 from BDI. Your file pedestal has been designed to provide a lifetime of enjoyment. This manual will provide you with assembly instructions and other helpful information that will ensure that you get the most out of your file pedestal. Please save it for future reference.

Your Sequel 20 File Pedestal has been engineered for simple assembly. Please follow these directions carefully to prevent any damage.

Should you need further assistance, contact BDI at customerservice@bdiusa.com.

ENJOY!

HARDWARE AND COMPONENTS

Unpack and identify the parts listed below. The assembly workspace should be a non-marring surface such as carpet. For missing hardware pieces, please contact BDI Customer Service at customerservice@bdiusa.com.

Do not use power tools for assembly of this product.

For all other concerns, please contact your BDI retailer.



PART #	H1
DESCRIPTION	M4 x 12mm Screw
QUANTITY	20

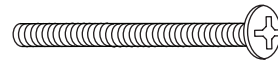

PART #	H2
DESCRIPTION	M4 x 35mm Screw
QUANTITY	6

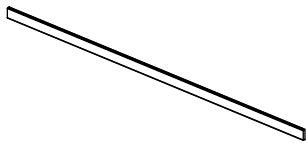

PART #	H4
DESCRIPTION	Small File Bar
QUANTITY	1



PART #	H5
DESCRIPTION	File Bar Clip
QUANTITY	2

HARDWARE AND COMPONENTS

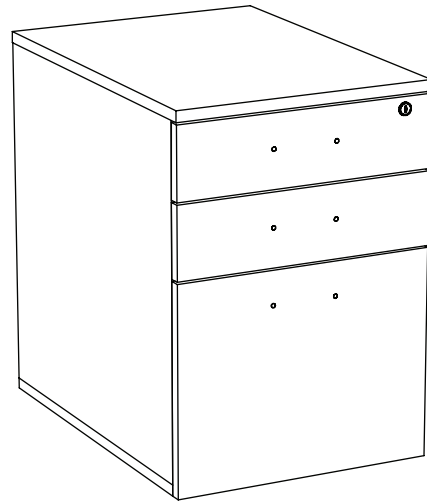

PART #	C1
DESCRIPTION	Cabinet
QUANTITY	1

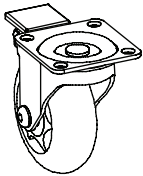

PART #	C2
DESCRIPTION	Locking Swivel Caster
QUANTITY	4

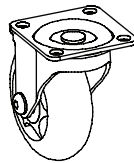

PART #	C3
DESCRIPTION	Swivel Caster
QUANTITY	1



PART #	C4
DESCRIPTION	Drawer Pull–Satin
QUANTITY	3

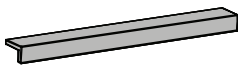

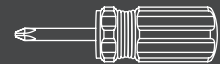

PART #	C5
DESCRIPTION	Drawer Pull–Black
QUANTITY	3



TOOL REQUIRED (NOT INCLUDED)

Phillips Screwdriver

Carefully position **(C1) Cabinet** onto its back. Install **(C2) Locking Swivel Casters** using **(H1) Screws** and **Phillips Screwdriver** (not included). Install **(C3) Swivel Caster** using **(H1) Screws** and **Phillips Screwdriver** (not included).

	PART/DESCRIPTION	QTY
	H1-SCREW	20
	NOT INCLUDED Phillips Screwdriver	1

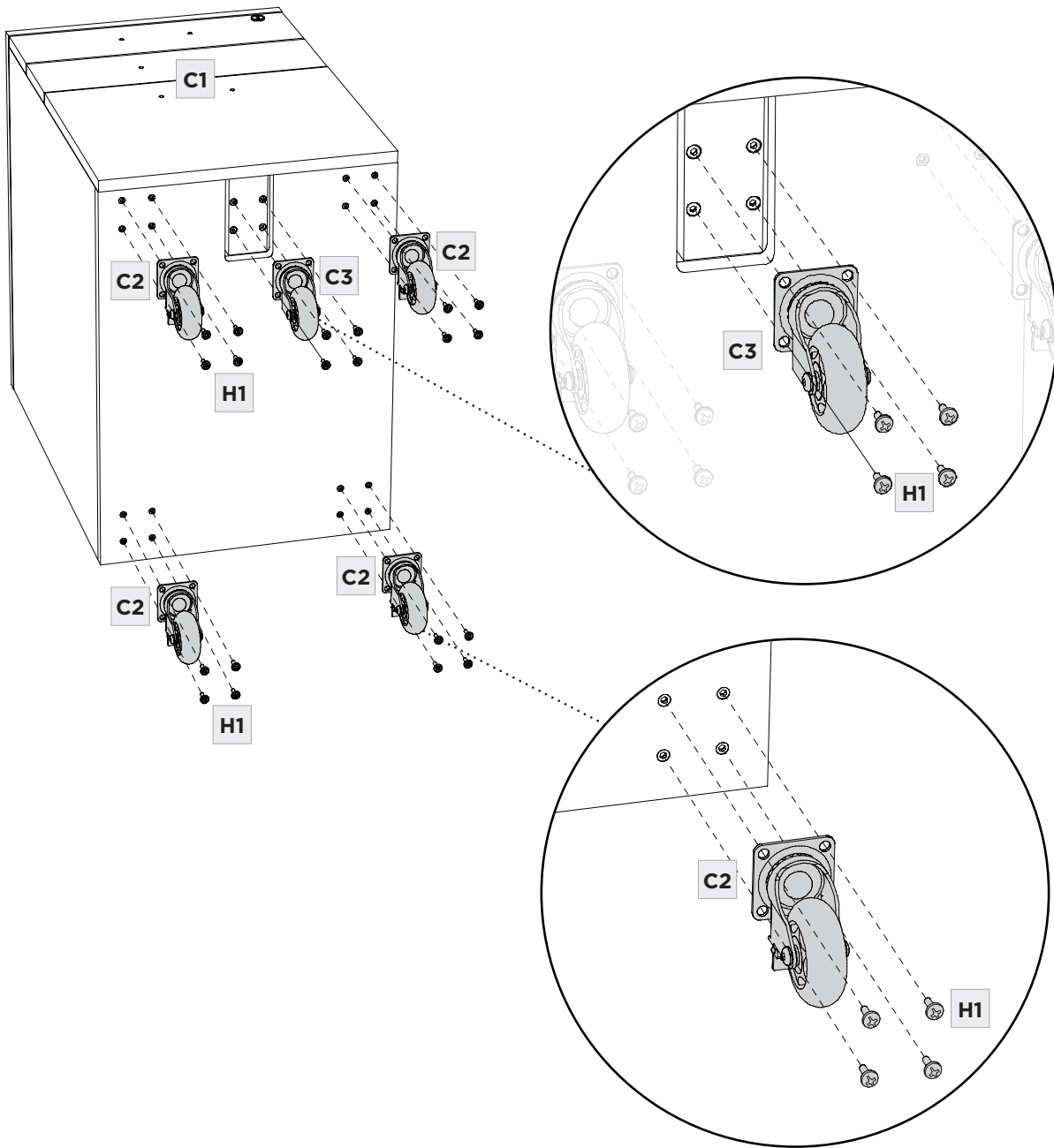

STEP 2. ATTACH DRAWER PULLS



ASSEMBLY

Choose drawer pull color, either **(C3) Satin Nickel** or **(C4) Black**. Open a drawer and connect a **(C3/C4) Drawer Pull** using **2 (H2) Screws**. Tighten with a **Phillips Screwdriver** (not included). Install the other **2 (C3/C4) Drawer Pulls**, one at a time.

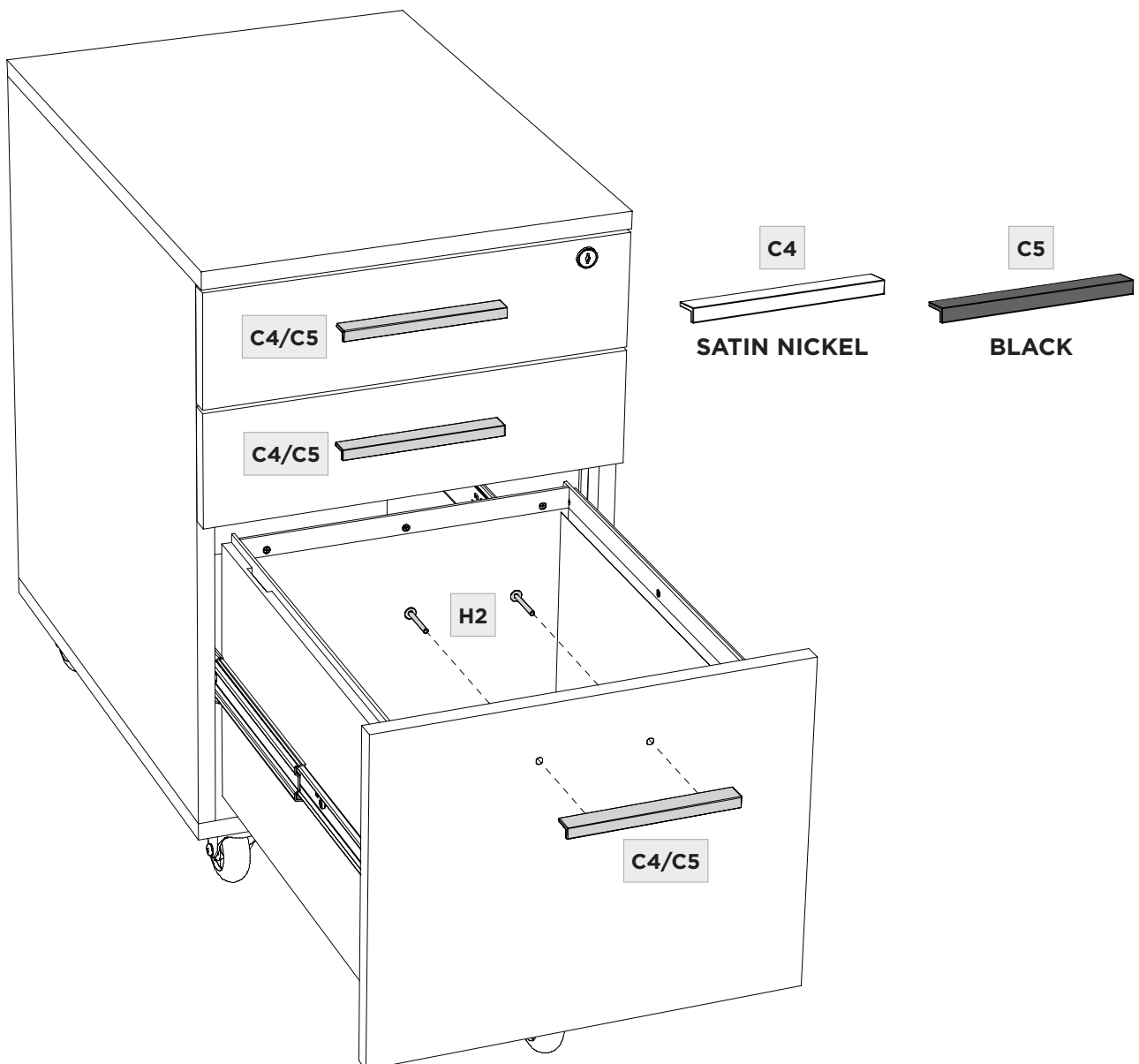
	PART/DESCRIPTION	QTY
	H2-Screw	6
	NOT INCLUDED Phillips Screwdriver	1



Letter sized file folders fit side-to-side as shown.
Legal sized file folders fit front-to-back. For **Letter** or **A4** files facing front-to-back, attach **(H5) File Bar Clip** to both ends of **(H4) Small File Bar** as shown. Place the file bar assembly in the notches located on the left and right drawer side panels. For **A4**, slide the file bar **backwards** within the notch.

	PART/DESCRIPTION	QTY
	H4-SMALL FILE BAR	1
	H5-FILE BAR CLIP	2

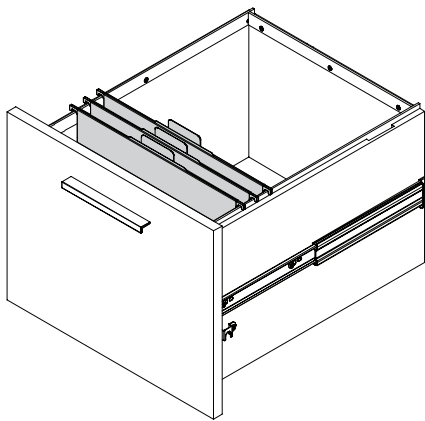

Letter
side-to-side

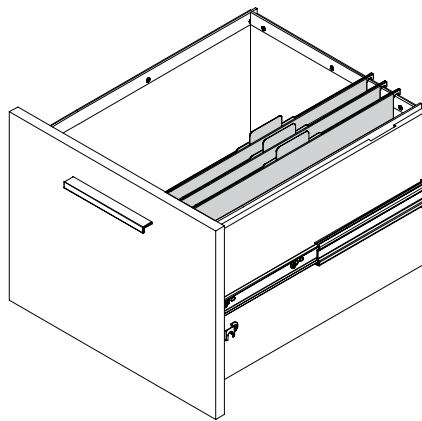

Legal
front-to-back

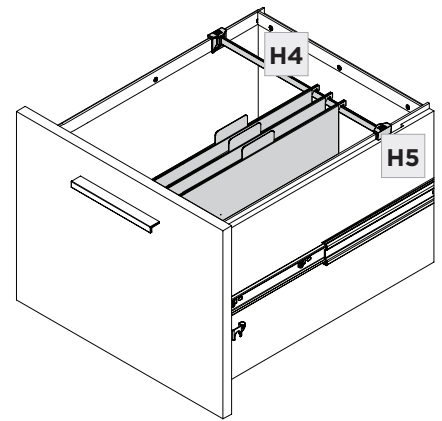

Letter/A4
front-to-back

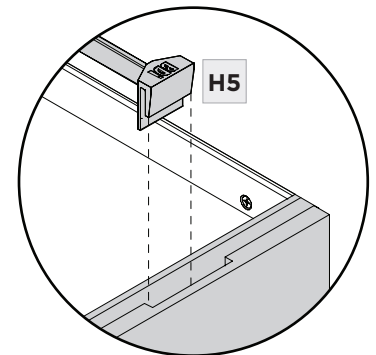
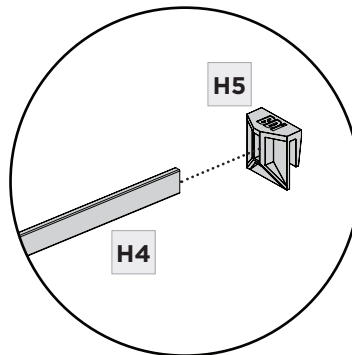
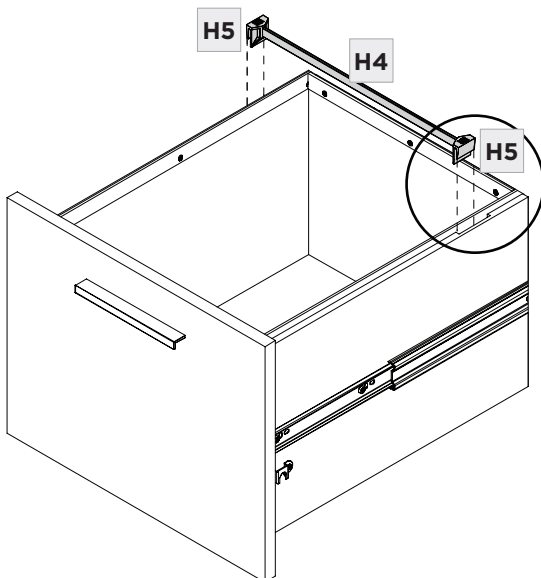

Letter/A4 notch

GLASS

Glass surface is maintained using household glass cleaner and a paper towel or cloth.

SATIN-ETCHED GLASS

This uniquely smooth-to-the-touch glass surface can be regularly maintained using household glass cleaner and a paper towel or cloth. Minor scratches or scuffs not eliminated using paper towel or cloth can usually be removed by using a 'Magic Eraser'. Magic Eraser is a melamine foam product available at any grocery store or home improvement center. Dampen the entire glass surface as well as the Magic Eraser, then rub the entire glass surface in broad, even strokes using moderate pressure. Clean and dry the surface with a paper towel. Check for results and repeat as necessary.

Any scratches or scuffing not eliminated by one of the above methods can often be addressed by 'refreshing' the glass. This is a process that should not be required more than once per 6-12 months. See this brief video for the simple method: www.bdiusa.com/glass

WOOD

Wood surfaces should be cleaned with a slightly damp (not saturated) cloth or paper towel. Do not use glass cleaner on wood. If moisture remains, dry the surface with another cloth. If needed, a gentle non-abrasive cleanser may be used, but be sure to wipe away all cleaner residue and dry the surface with a cloth.

BDI's wood finishes feature natural hardwood solids and veneers. Wood is a product of nature and—unlike man-made materials that can be manufactured to strict and consistent specifications—has natural imperfections that are part of its appeal and character. Every piece of wood differs from every other, even when coming from the very same tree. As such, variation in grain, texture and tone should be expected from one panel or piece of furniture to the next.

While BDI's stained wood finishes are stable in tone & appearance, all finishes are subject to some degree of discoloration with prolonged exposure to direct sunlight. Please take care to avoid positioning your BDI cabinet in any area with extensive direct sunlight. To learn more about the features of natural wood, visit www.bdiusa.com/wood

METAL & PAINTED SURFACES

Surfaces should be cleaned with a slightly damp (not saturated) cloth or paper towel. If moisture remains, dry the surface with another cloth. If needed, a gentle non-abrasive cleanser may be used, but be sure to wipe away all cleaner residue and dry the surface with a cloth.

WARRANTY

BDI warrants to the original purchaser that for the below-stated warranty term, BDI will replace any product, part, or component covered by this warranty that fails under normal use as a result of a defect in material or workmanship. The decision to replace a complete product versus the part or component in question will be at BDI's sole discretion.

Residential Use: BDI Furnishings carry warranty coverage for three (3) years from the date of product delivery, as shown on your sales receipt/documentation. Select chairs carry coverage for five (5) years from the date of product delivery.

Commercial Use: BDI Furnishings carry warranty coverage for one (1) year from the date of product delivery, as shown on your sales receipt/documentation. Select chairs carry coverage for five (5) years from the date of the product delivery, based on an 8-hour daily use pattern.

BDI reserves the right to refine or update its warranty from time to time. See the complete and latest warranty document at www.bdiusa.com/warranty.

PRODUCT REGISTRATION

Registering your new BDI product allows us to send you important product updates, service information and helpful hints related to your BDI products. Register today, and you will be entered to win free a BINK table from BDI: www.bdiusa.com/register



WARNING

SERIOUS OR FATAL CRUSHING INJURIES CAN OCCUR FROM FURNITURE TIP-OVER. TO HELP PREVENT TIP-OVER:

- Install tip-over restraint.
- Place heaviest items in lower compartments.
- Never allow children to climb or hang on drawers, doors or shelves.
- Never open more than one drawer at a time.

USE OF TIP-OVER RESTRAINT MAY REDUCE—BUT NOT ELIMINATE—THE RISK OF TIP-OVER.



BDIUSA.COM

These distinctive product configurations are protected by US and international patents, trade dress, and/or copyright laws. Sequel & BDI are trademarks of Becker Designed, Inc. All rights reserved. ©2020, BDI | V.05.15.2020

Made in Vietnam.