

# SEQUEL<sup>®</sup> 20 6112

RETURN

## INSTRUCTION MANUAL

**LET'S GET STARTED.**

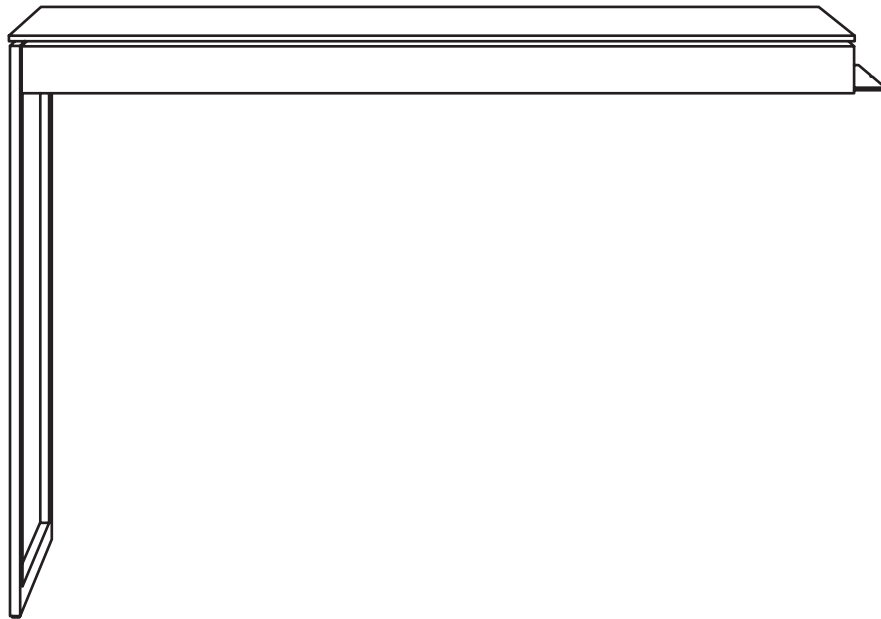

DESIGN MATTHEW WEATHERLY

**BDi**

BDIUSA.COM



Congratulations on the purchase of your Sequel 20 Return 6112 from BDI. Your return has been designed to provide a lifetime of enjoyment. This manual will provide you with assembly instructions and other helpful information that will ensure that you get the most out of your return. Please save it for future reference.

Your Sequel 20 Return has been engineered for simple assembly. Please follow these directions carefully to prevent any damage.

Should you need further assistance, contact BDI at [customerservice@bdiusa.com](mailto:customerservice@bdiusa.com).

ENJOY!

## HARDWARE AND COMPONENTS

Unpack and identify the parts listed below. The assembly workspace should be a non-marring surface such as carpet. For missing hardware pieces, please contact BDI Customer Service at [customerservice@bdiusa.com](mailto:customerservice@bdiusa.com).

Do not use power tools for assembly of this product.

For all other concerns, please contact your BDI retailer.



PART #	<b>T1</b>
DESCRIPTION	Hex Wrench
QUANTITY	1

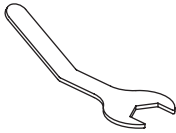

PART #	<b>T2</b>
DESCRIPTION	Hex Wrench
QUANTITY	1

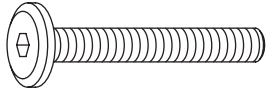

PART #	<b>H1</b>
DESCRIPTION	M6 x 40mm Screw
QUANTITY	4

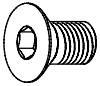

PART #	<b>H2</b>
DESCRIPTION	M6 x 10mm Flathead Screw
QUANTITY	4

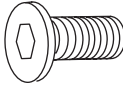

PART #	<b>H3</b>
DESCRIPTION	M6 x 15mm Screw
QUANTITY	5



PART #	<b>H4</b>
DESCRIPTION	Leveler
QUANTITY	2

**HARDWARE AND COMPONENTS**

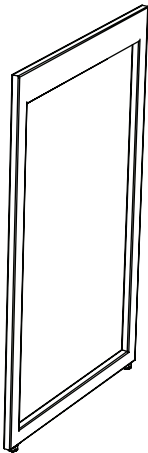

PART #	<b>C1</b>
DESCRIPTION	Leg Frame
QUANTITY	1

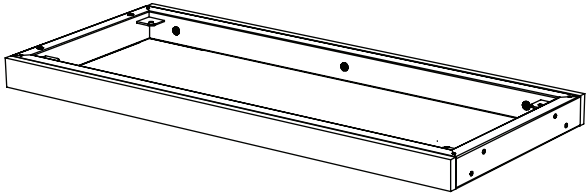

PART #	<b>C2</b>
DESCRIPTION	Top Frame
QUANTITY	1

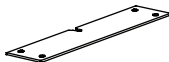

PART #	<b>C3</b>
DESCRIPTION	Connector Plate
QUANTITY	1

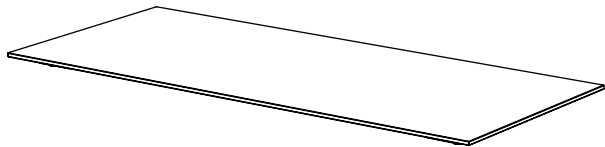

PART #	<b>C4</b>
DESCRIPTION	Top Panel
QUANTITY	1

**ASSEMBLY****STEP 1. INSTALL LEVELERS**

Install **(H4) Levelers** into the bottom of **(C1) Leg Frame**.

	PART/DESCRIPTION	QTY
	H4-LEVELER	2

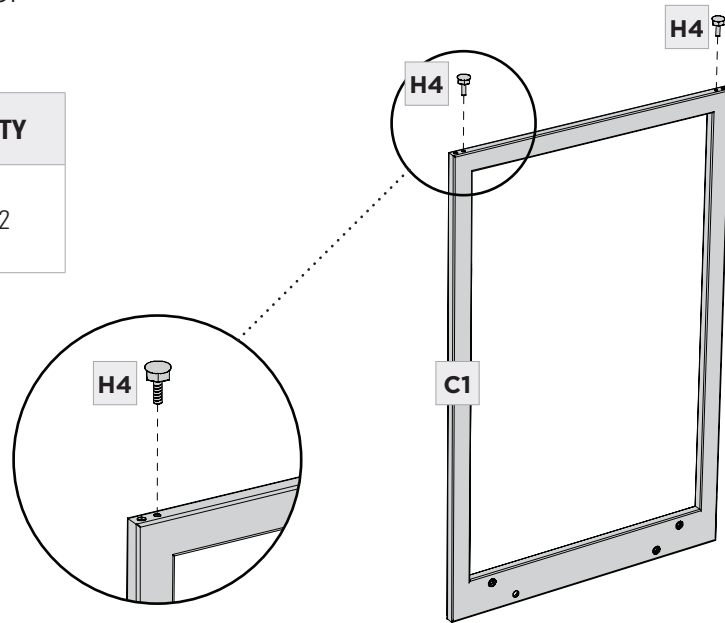
**ASSEMBLY****STEP 2. INSTALL TOP FRAME**

Connect **(C1) Leg Frame** to **(C2) Top Frame** using **4 (H1) Screws** and tighten with **(T1) Hex Wrench**.

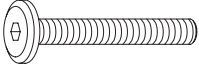
	PART/DESCRIPTION	QTY
	T1-HEX WRENCH	1
	H1-SCREW	4

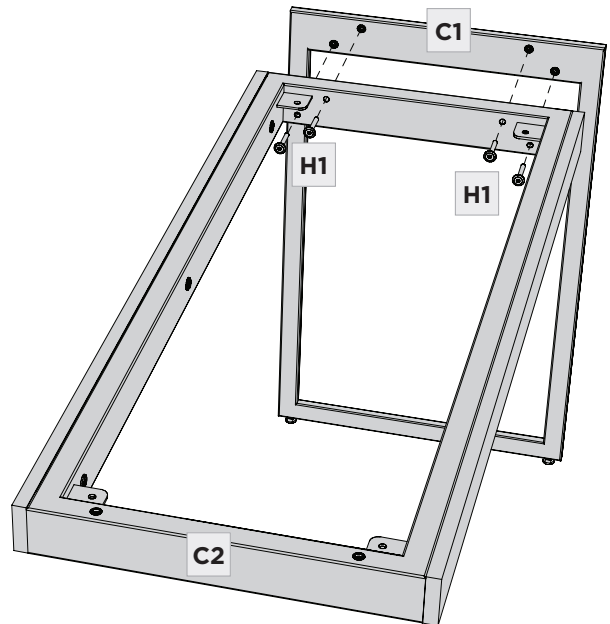



## STEP 3. INSTALL CONNECTOR PLATE

## ASSEMBLY

The return may be attached to either a desk or a cabinet.

IF ATTACHING TO A DESK—  
COMPATIBLE WITH 6101, 6102:

Connect the **(C3) Connector Plate** to the underside of **(C2) Top Frame** using **2 (H2) Flathead Screws** and **(T1) Hex Wrench**. Make sure notch is facing outward. **Go to step 4.**

	PART/DESCRIPTION	QTY
	T1-HEX WRENCH	1
	H2-FLATHEAD SCREW	2

IF ATTACHING TO A CABINET—  
COMPATIBLE WITH 6114, 6116, 6117:

Connect the **(C3) Connector Plate** to the topside of **(C2) Top Frame** using **2 (H2) Flathead Screws**. Make sure notch is facing outward. **Go to step 8.**

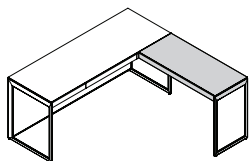

Connecting to desk  
plate goes on bottom

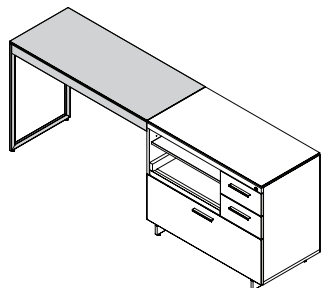

Connecting to cabinet  
plate goes on the top

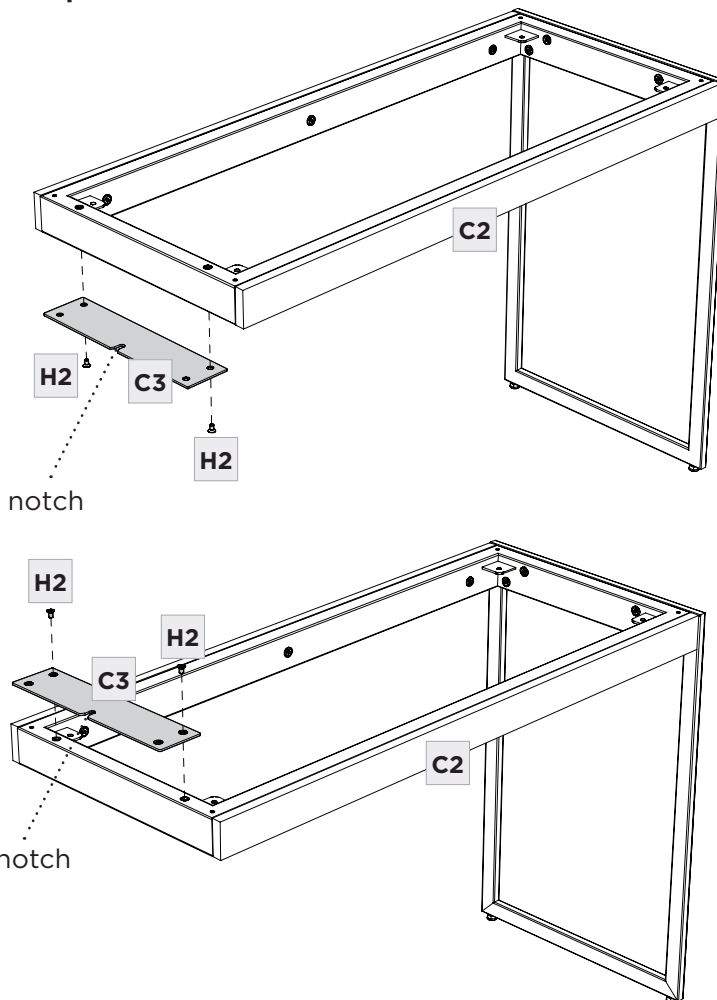

The return may be attached either to the **left** or **right** of the center drawer (**right side shown below**). Partially thread **1 (H3) Screw** into the **middle insert** leaving it extended out **1/4" (6mm)** to allow **(C3) Connector Plate** to slide into the space between the screw head and bottom of the desk.

	PART/DESCRIPTION	QTY
	H3-SCREW	1

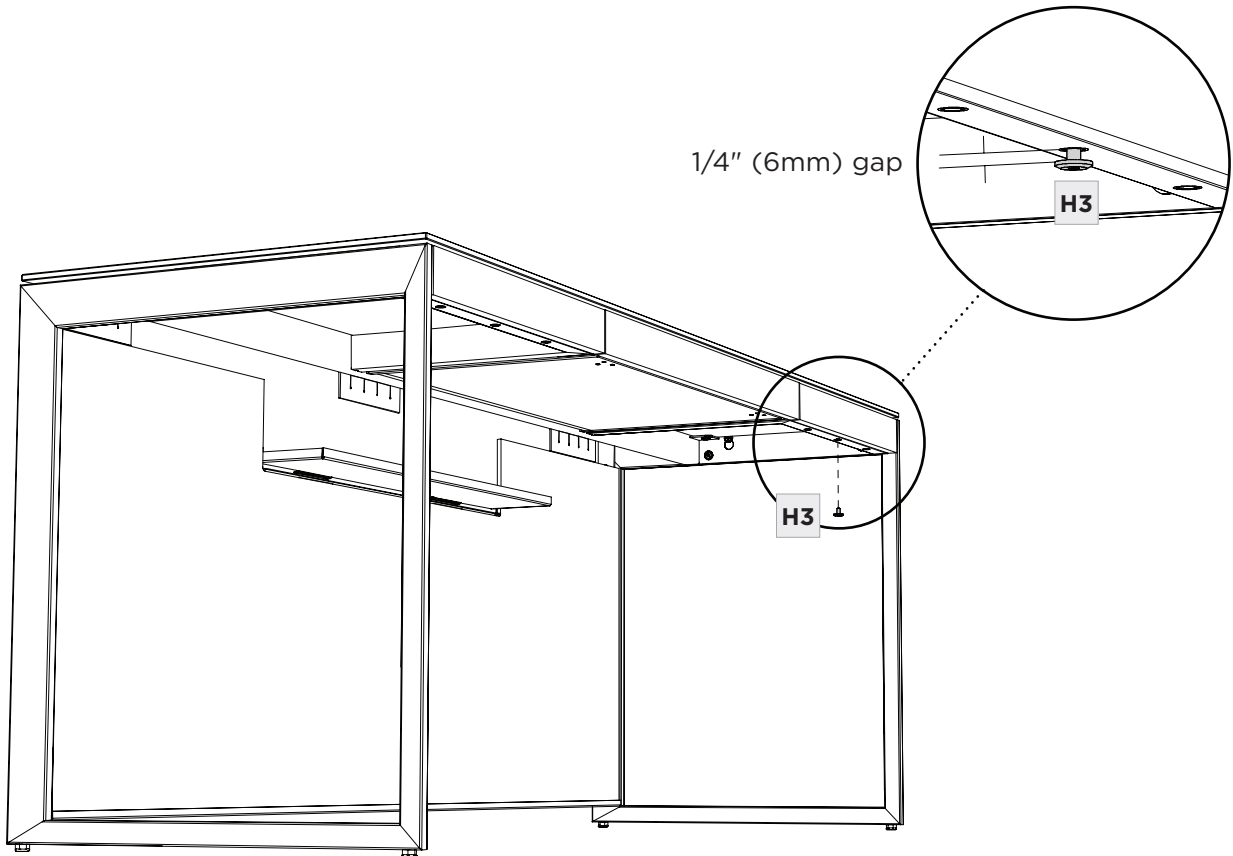

## STEP 5. ATTACH THE RETURN

## ASSEMBLY

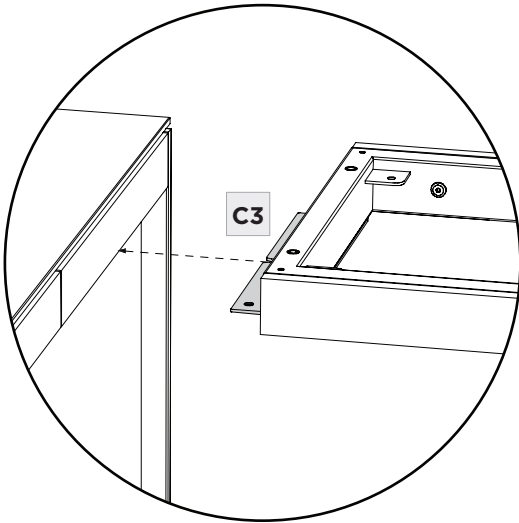

Slide the notch on **(C3) Connector Plate** onto the partially threaded **middle screw**. Tighten the screw with **(T1) Hex Wrench**.



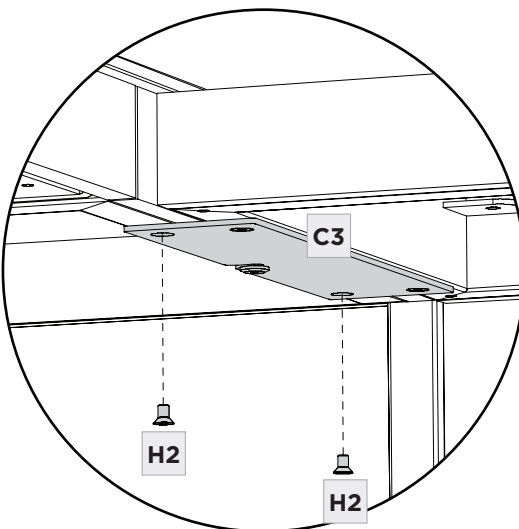

	PART/DESCRIPTION	QTY
	T1-HEX WRENCH	1

Insert **(H2) Flathead Screws** into the left and right holes on the **(C3) Connector Plate** and tighten with **(T1) Hex Wrench**.



	PART/DESCRIPTION	QTY
	T1-HEX WRENCH	1
	H2-FLATHEAD SCREW	2

Attach **(C4) Top Panel** by placing it on top of the return and fastening with **(H3) Screws** going through the metal tabs in the corners and into the inserts on the underside of the **(C4) Top Panel**. Make sure the gap between desk glass and return glass is even, then tighten with **(T1) Hex Wrench**.

	PART/DESCRIPTION	QTY
	T1-HEX WRENCH	1
	H3-SCREW	4

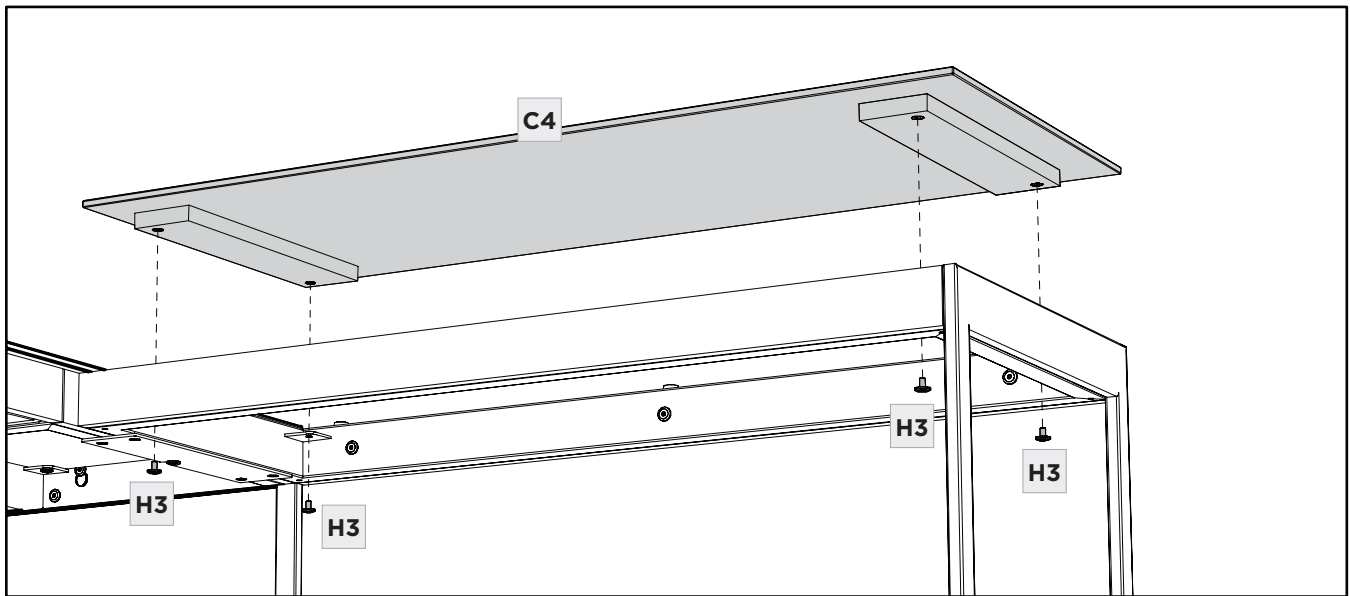



## STEP 7. INSTALL TOP PANEL

## ASSEMBLY

The return may be attached to the left or right side of the following cabinets:

- 6114 3 Drawer File Pedestal
- 6116 Lateral File
- 6117 Multi-Function Cabinet—shown below

First, remove the glass top from the cabinet. Attach the **(C3) Connector Plate** to the cabinet using **(H2) Flathead Screws** going through the **(C3) Connector Plate** and into the 2 threaded holes on the top of the cabinet. Tighten with **(T1) Hex Wrench**. Re-install the glass top onto the cabinet.

	PART/DESCRIPTION	QTY
	T1-HEX WRENCH	1
	H2-FLATHEAD SCREW	2

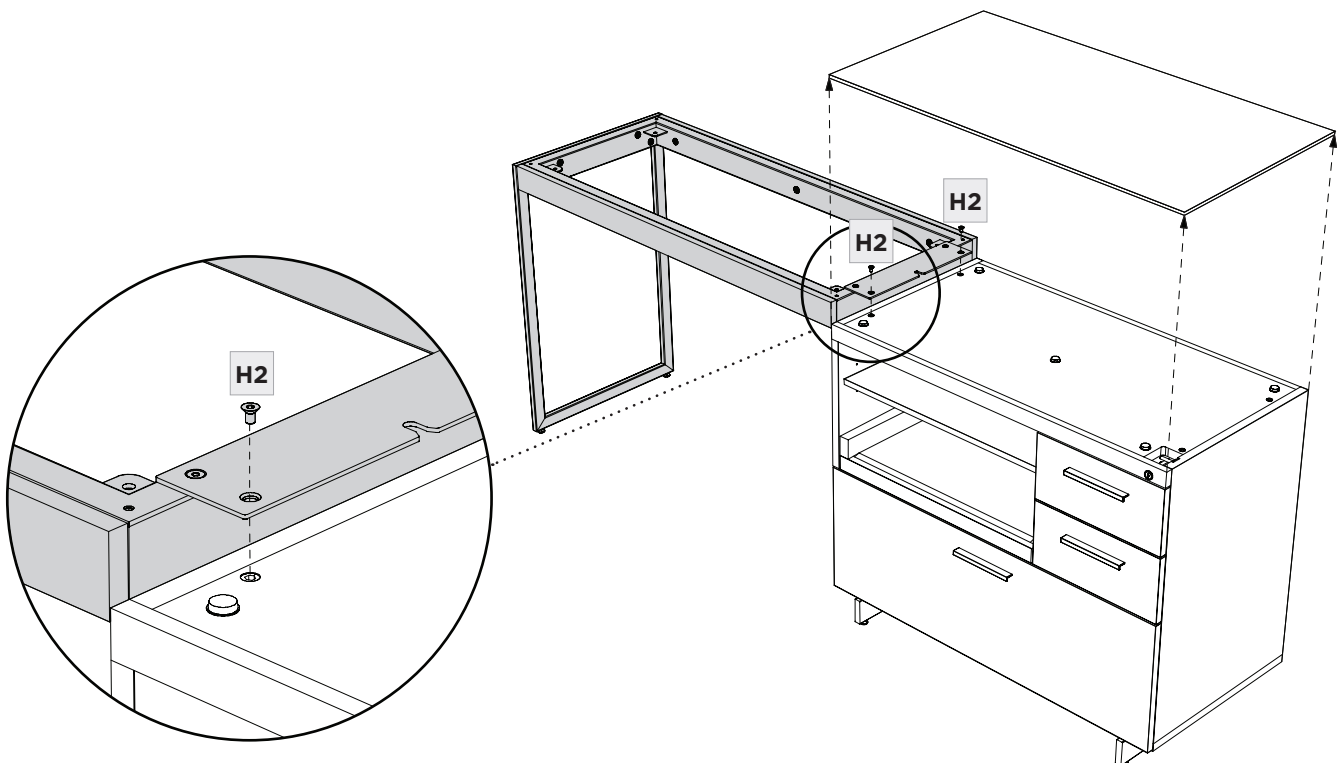

Attach **(C4) Top Panel** by placing it on top of the return and fastening with **(H3) Screws** going through the metal tabs in the corners and into the inserts on the underside of the **(C4) Top Panel**. Make sure the gap between desk glass and return glass is even, then tighten with **(T1) Hex Wrench**.

	PART/DESCRIPTION	QTY
	T1-HEX WRENCH	1
	H3-SCREW	4

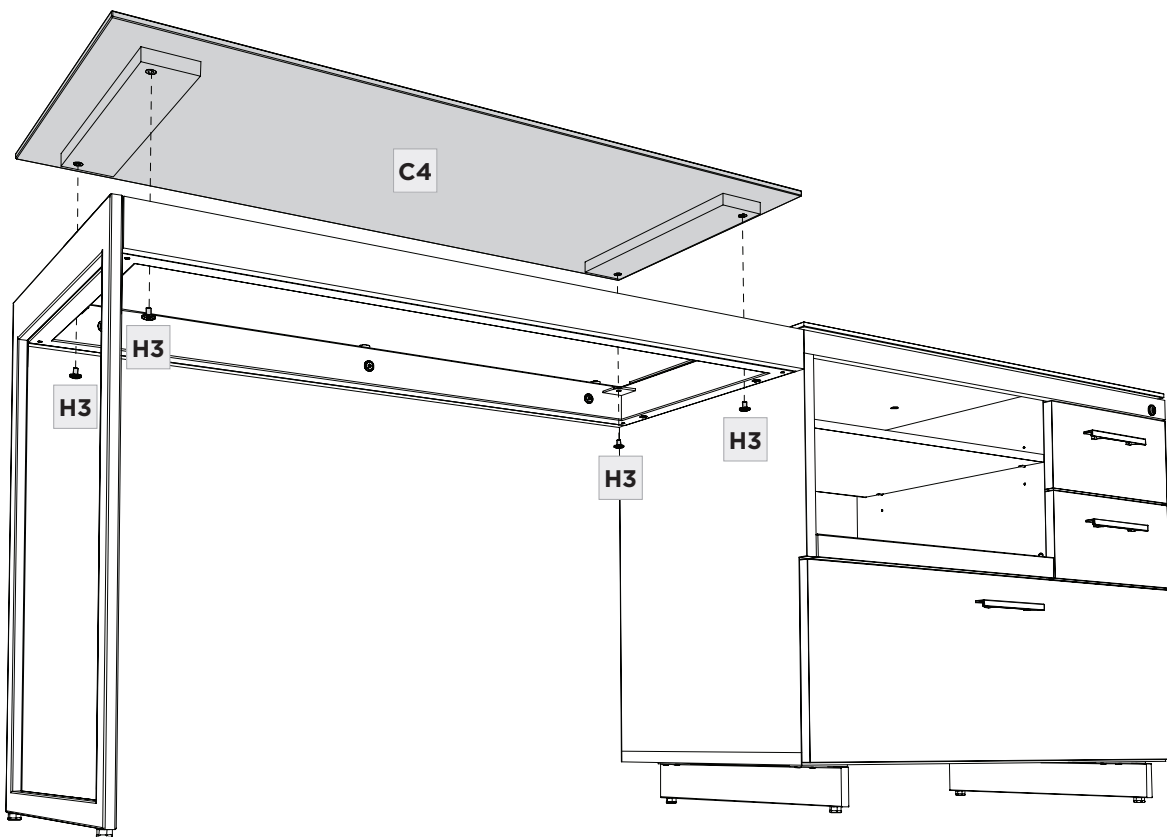

### GLASS

Glass surface is maintained using household glass cleaner and a paper towel or cloth.

### SATIN-ETCHED GLASS

This uniquely smooth-to-the-touch glass surface can be regularly maintained using household glass cleaner and a paper towel or cloth. Minor scratches or scuffs not eliminated using paper towel or cloth can usually be removed by using a 'Magic Eraser'. Magic Eraser is a melamine foam product available at any grocery store or home improvement center. Dampen the entire glass surface as well as the Magic Eraser, then rub the entire glass surface in broad, even strokes using moderate pressure. Clean and dry the surface with a paper towel. Check for results and repeat as necessary.

Any scratches or scuffing not eliminated by one of the above methods can often be addressed by 'refreshing' the glass. This is a process that should not be required more than once per 6-12 months. See this brief video for the simple method: [www.bdiusa.com/glass](http://www.bdiusa.com/glass)

### WOOD

Wood surfaces should be cleaned with a slightly damp (not saturated) cloth or paper towel. Do not use glass cleaner on wood. If moisture remains, dry the surface with another cloth. If needed, a gentle non-abrasive cleanser may be used, but be sure to wipe away all cleaner residue and dry the surface with a cloth.

BDI's wood finishes feature natural hardwood solids and veneers. Wood is a product of nature and—unlike man-made materials that can be manufactured to strict and consistent specifications—has natural imperfections that are part of its appeal and character. Every piece of wood differs from every other, even when coming from the very same tree. As such, variation in grain, texture and tone should be expected from one panel or piece of furniture to the next.

While BDI's stained wood finishes are stable in tone & appearance, all finishes are subject to some degree of discoloration with prolonged exposure to direct sunlight. Please take care to avoid positioning your BDI cabinet in any area with extensive direct sunlight. To learn more about the features of natural wood, visit [www.bdiusa.com/wood](http://www.bdiusa.com/wood)

### METAL & PAINTED SURFACES

Surfaces should be cleaned with a slightly damp (not saturated) cloth or paper towel. If moisture remains, dry the surface with another cloth. If needed, a gentle non-abrasive cleanser may be used, but be sure to wipe away all cleaner residue and dry the surface with a cloth.

## WARRANTY

BDI warrants to the original purchaser that for the below-stated warranty term, BDI will replace any product, part, or component covered by this warranty that fails under normal use as a result of a defect in material or workmanship. The decision to replace a complete product versus the part or component in question will be at BDI's sole discretion.

**Residential Use:** BDI Furnishings carry warranty coverage for three (3) years from the date of product delivery, as shown on your sales receipt/documentation. Select chairs carry coverage for five (5) years from the date of product delivery.

**Commercial Use:** BDI Furnishings carry warranty coverage for one (1) year from the date of product delivery, as shown on your sales receipt/documentation. Select chairs carry coverage for five (5) years from the date of the product delivery, based on an 8-hour daily use pattern.

BDI reserves the right to refine or update its warranty from time to time. See the complete and latest warranty document at [www.bdiusa.com/warranty](http://www.bdiusa.com/warranty).

## PRODUCT REGISTRATION

Registering your new BDI product allows us to send you important product updates, service information and helpful hints related to your BDI products. Register today, and you will be entered to win free a BINK table from BDI: [www.bdiusa.com/register](http://www.bdiusa.com/register)



# WARNING

**SERIOUS OR FATAL CRUSHING INJURIES CAN OCCUR FROM FURNITURE TIP-OVER. TO HELP PREVENT TIP-OVER:**

- Install tip-over restraint.
- Place heaviest items in lower compartments.
- Never allow children to climb or hang on drawers, doors or shelves.
- Never open more than one drawer at a time.

**USE OF TIP-OVER RESTRAINT MAY REDUCE—BUT NOT ELIMINATE—THE RISK OF TIP-OVER.**





These distinctive product configurations are protected by US and international patents, trade dress, and/or copyright laws. Sequel & BDI are trademarks of Becker Designed, Inc. All rights reserved. ©2020, BDI | V.08.21.2020

Made in Vietnam.

# SEQUEL<sup>®</sup> STUDIO 6617

MULTIFUNCTION CABINET

## USER MANUAL

LET'S GET STARTED.

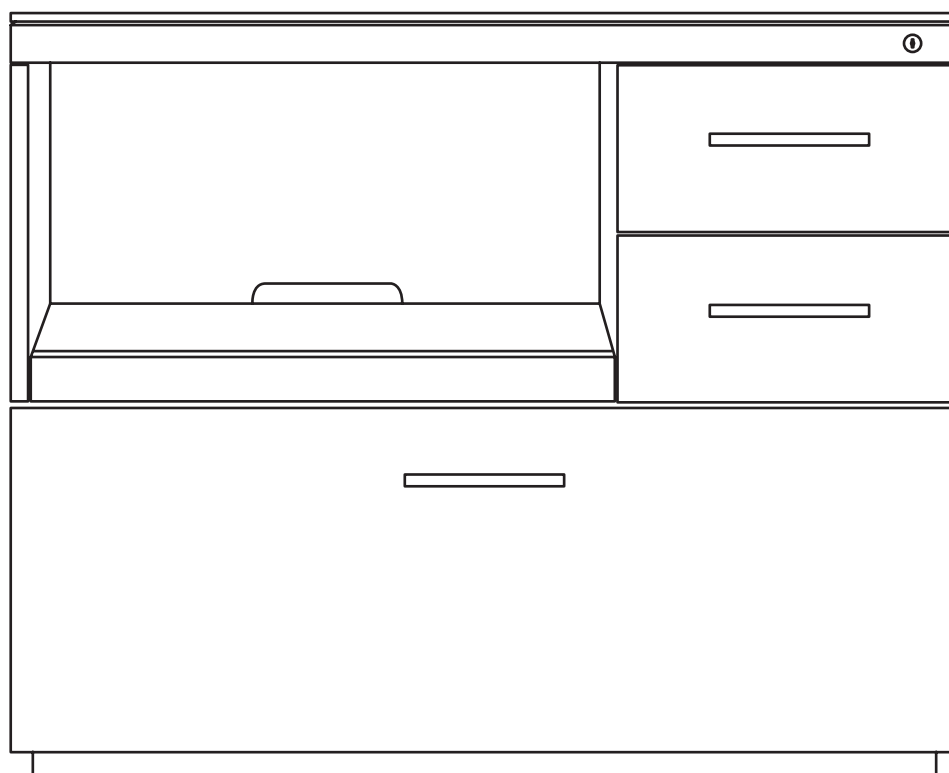

DESIGN MATTHEW WEATHERLY

**BDi**

BDIUSA.COM



Congratulations on the purchase of your Sequel Studio cabinet from BDI. Your multifunction cabinet has been designed to provide a lifetime of enjoyment. This manual will provide assembly instructions and other helpful information to ensure you get the most out of your product. Please save it for future reference.

Your Sequel Studio has been engineered for simple assembly. Please follow these directions carefully to prevent any damage.

Should you need further assistance, contact BDI at [customerservice@bdiusa.com](mailto:customerservice@bdiusa.com).

ENJOY!

## HARDWARE AND COMPONENTS

Unpack and identify the parts listed below. The assembly workspace should be a non-marring surface, such as carpet. For missing hardware pieces, please contact BDI Customer Service at [customerservice@bdiusa.com](mailto:customerservice@bdiusa.com). For all other concerns, please contact your BDI retailer.

Do not use power tools for the assembly of this product.

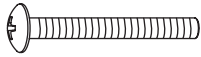

M4 x 35 Screw (H1)

QTY: 6

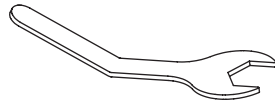

Leveler Wrench (T1)

QTY: 1



**TOOL REQUIRED (NOT INCLUDED)**

Phillips Screwdriver

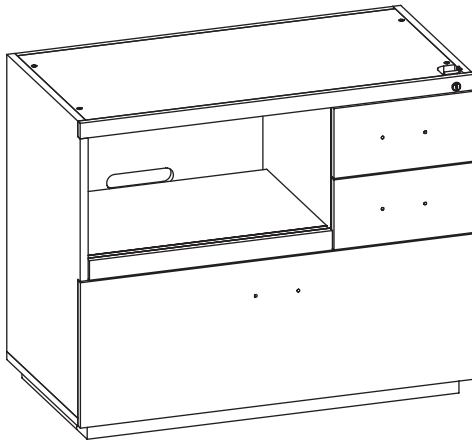

Cabinet (C1)

QTY: 1



Drawer Pull (C2)

QTY: 3

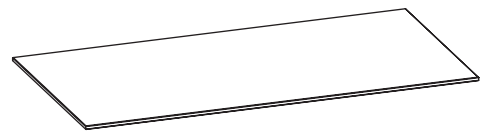

Glass Top (C3)

QTY: 1



Small File Bar (C4)

QTY: 2

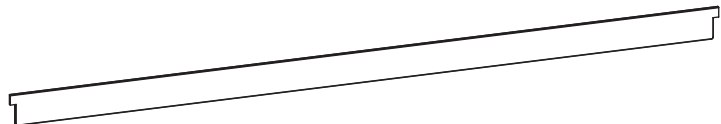

Long File Bar (C5)

QTY: 1





File Bar Clip (C6)

QTY: 4

## STEP 1. ATTACH DRAWER PULLS

## ASSEMBLY

- Open drawers of **Cabinet (C1)** and cut ribbons off.
- Attach **3 Pulls (C2)** with **6 Screws (H1)** using a **Phillips Screwdriver (not included)**.

	SCREW – H1	QTY 6
	<b>NOT INCLUDED</b> Phillips Screwdriver	1

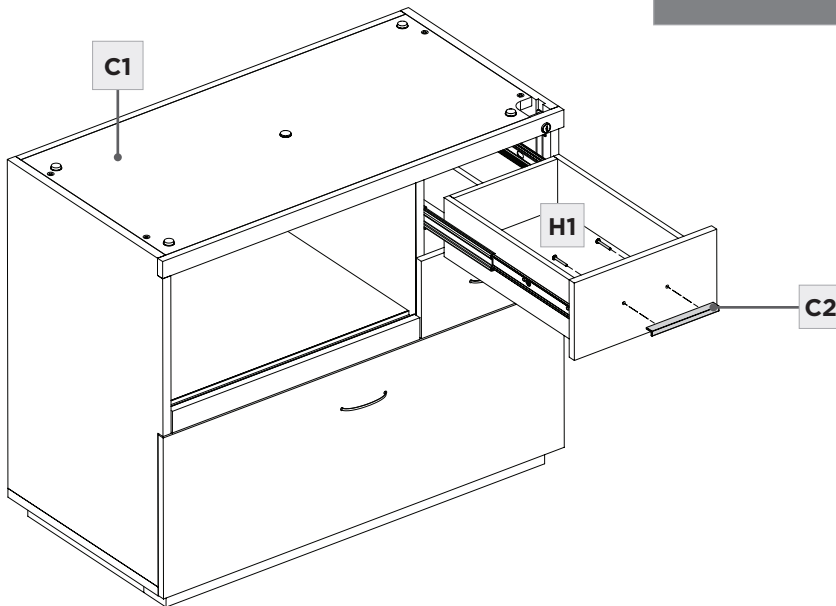

## STEP 2. PLACE GLASS TOP

## ASSEMBLY

- Carefully place **Glass Top (C3)** in position on rubber bumpers.

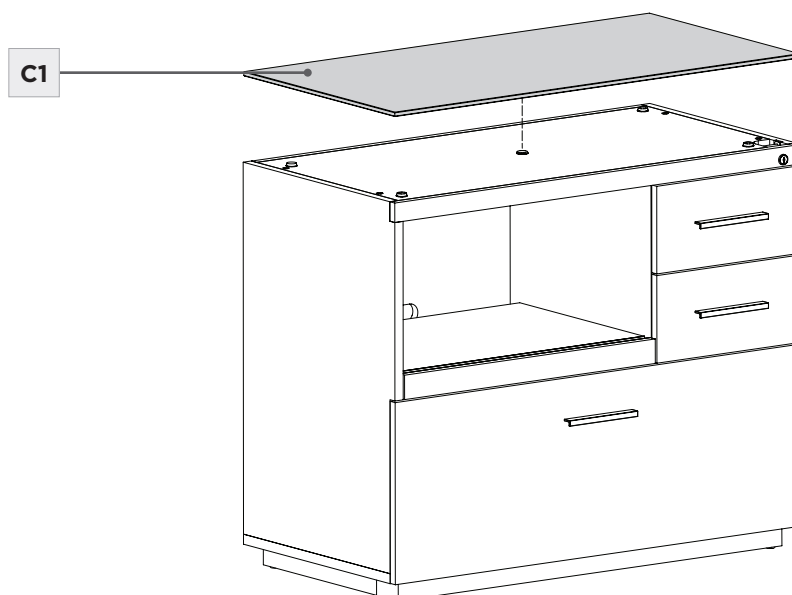

- Your Multifunction Cabinet can accommodate Letter, A4, and Legal file size.
- Please refer to the images and instructions below to place the File Bars in the correct locations.

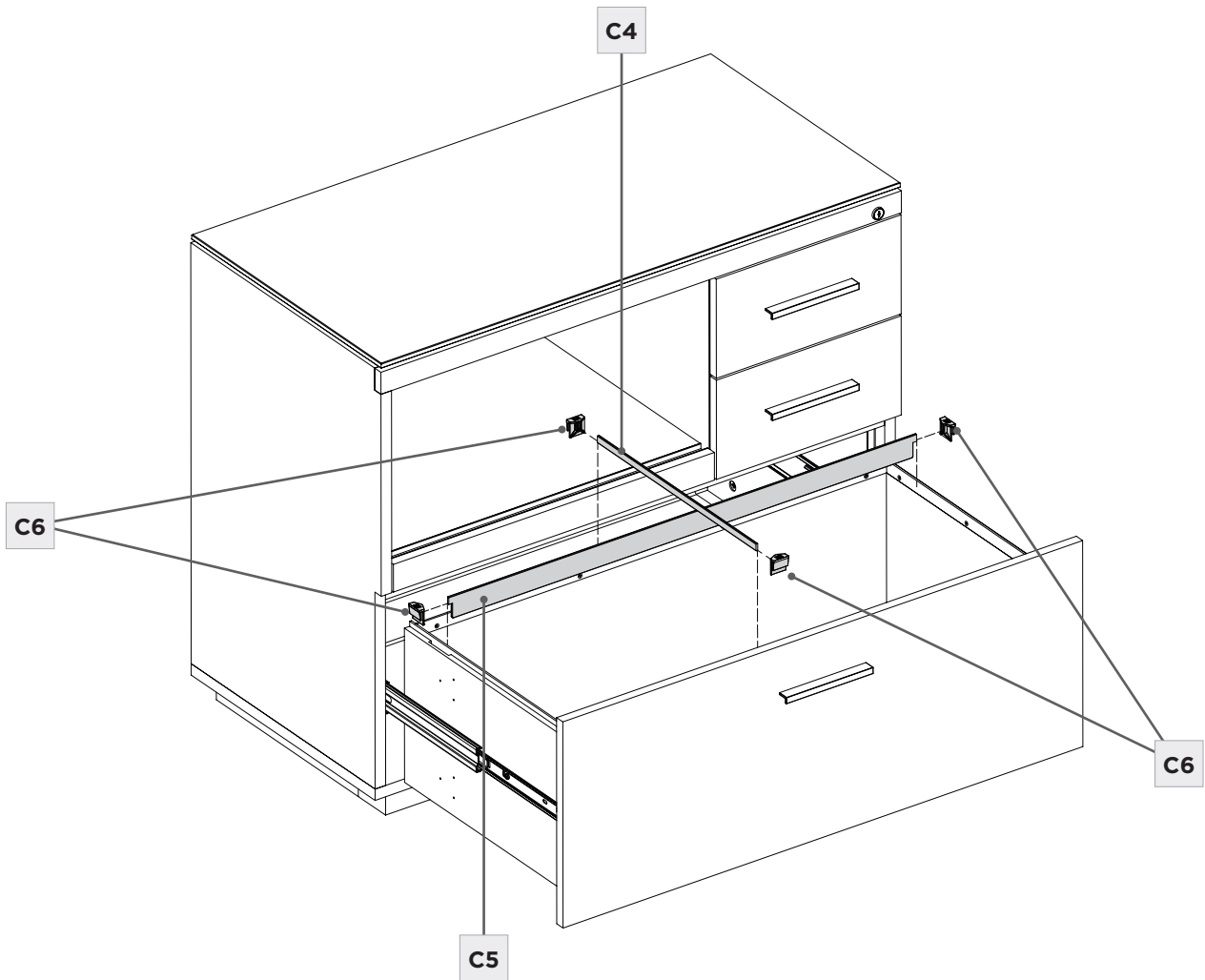

- For forward facing files, attach **File Bar Clips (C6)** to each end of **Small File Bars (C4)**.
- Place **File Bars** such that the **File Bar Clips** go into the appropriate grooves in the drawer's front and back panels.

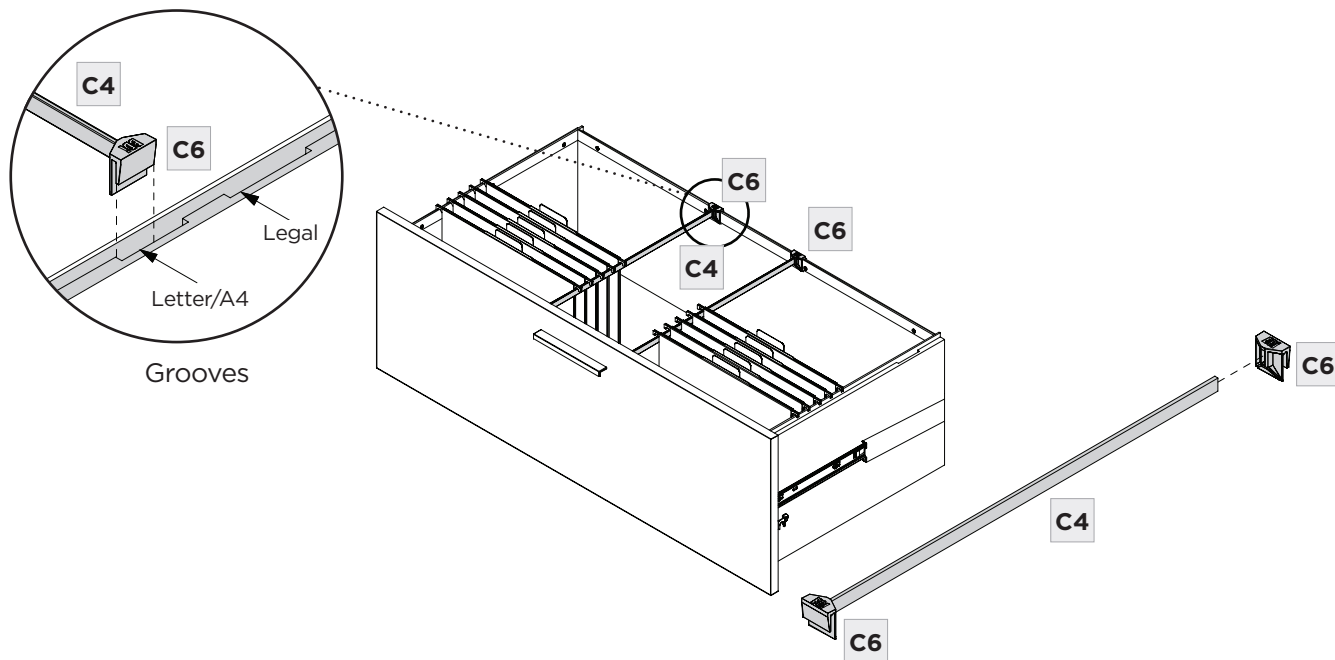

- For sideways facing letter files, attach **File Bar Clips (C6)** to each end of **Long File Bar (C5)**.
- Place the **Long File Bar** such that the **File Bar Clips** go into the grooves in the drawer's side panels.
- For side facing legal files, do not use a file bar at all. Simply hang the files on the drawer's front and back rails.

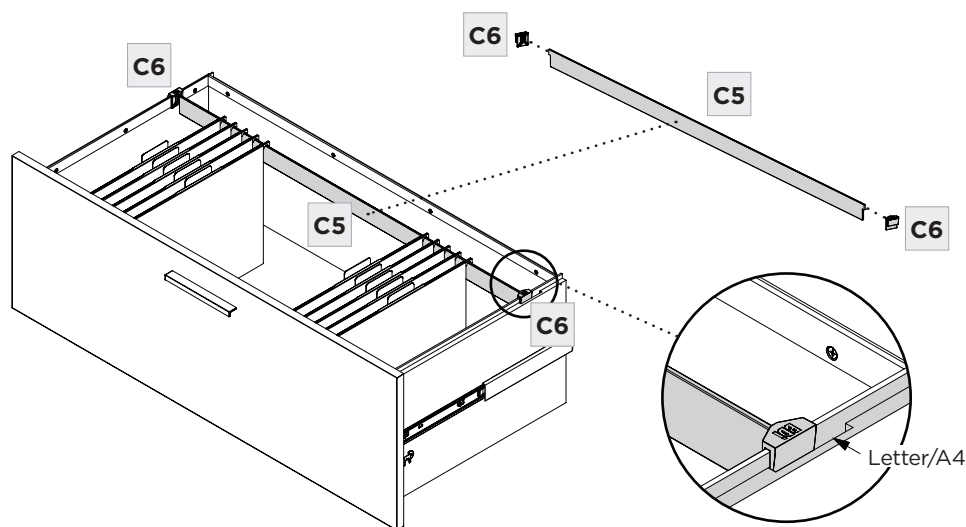

- Using a level (not provided), check that the cabinet is level side to side and front to back.
- If adjustments are needed, use the **Leveler Wrench (T1)** to fine-tune the levelers until the cabinet is properly balanced.
- For carpeted surfaces, recheck front-to-back leveling after loading the cabinet and opening the drawer.
- This ensures the cabinet remains level during use and minimizes risk of tip-over.

	LEVELER WRENCH – T1	1
---	---------------------	---

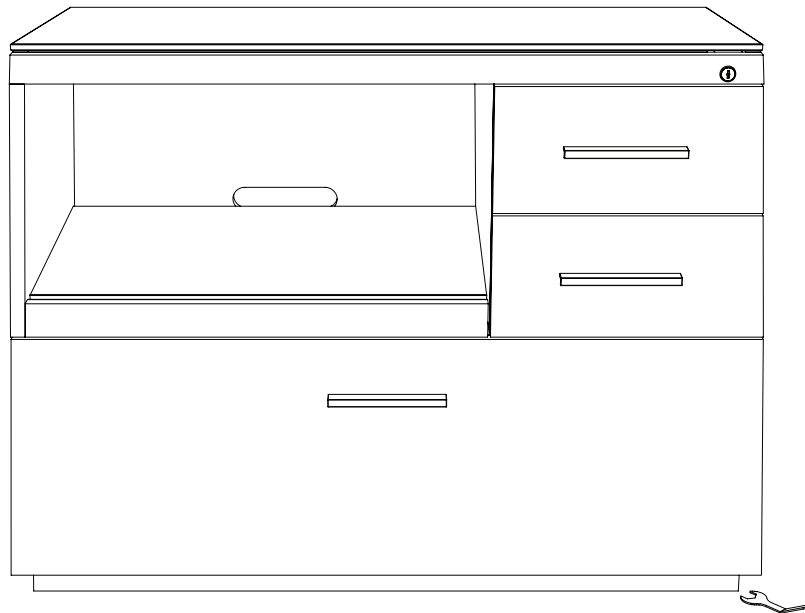

Your BDI furniture has been constructed with the finest materials, carefully manufactured, and designed to last a lifetime. Regular furniture care will prolong your enjoyment and keep it looking its best. Here are some general tips for taking care of BDI furniture. Your surfaces may vary.

### **GLASS**

Glass surfaces are maintained using household glass cleaner and a paper towel or cloth.

### **SATIN-ETCHED GLASS**

This uniquely smooth-to-the-touch glass surface can be regularly maintained using household glass cleaner and a paper towel or cloth.

A 'Magic Eraser' removes minor scratches or scuffs not eliminated using a paper towel or cloth. 'Magic Eraser' is a melamine foam product available at any grocery store or home improvement center. Dampen the entire glass surface and the Magic Eraser, then rub the whole surface in broad, even strokes using moderate pressure. Clean and dry the surface with a paper towel. Check for results and repeat as necessary. Any scratches or scuffing not eliminated by one of the above methods can often be addressed by 'refreshing' the glass. This process should not be required more than once per 6-12 months. See this brief video for the simple method: [www.bdiusa.com/glass](http://www.bdiusa.com/glass)

### **WOOD**

Wood surfaces should be cleaned with a slightly damp (not saturated) cloth or paper towel. Do not use glass cleaner on wood. If moisture remains, dry the surface with another cloth. If needed, a gentle, non-abrasive cleanser may be used, but wipe away all cleaner residue and dry the surface with a cloth.

BDI's wood finishes feature natural hardwood solids and veneers. Wood is a product of nature and—unlike man-made materials that can be manufactured to strict and consistent specifications—has natural imperfections that are part of its appeal and character. Every piece of wood differs from every other, even when coming from the very same tree. As such, grain, texture, and tone variation should be expected from one panel or piece of furniture to the next.

While BDI's stained wood finishes are stable in tone & appearance, all finishes are subject to some degree of discoloration with prolonged exposure to direct sunlight. Please avoid positioning your BDI cabinet in any area with ample direct sunlight. To learn more about the features of natural wood, visit [www.bdiusa.com/wood](http://www.bdiusa.com/wood)

### **METAL, PORCELAIN, & PAINTED SURFACES**

Surfaces should be cleaned with a slightly damp (not saturated) cloth or paper towel. If moisture remains, dry the surface with another cloth. If needed, a gentle, non-abrasive cleanser may be used, but be sure to wipe away all cleaner residue and dry the surface with a cloth.

## WARRANTY

BDI warrants to the original purchaser that for the below-stated warranty term, BDI will replace any product, part, or component covered by this warranty that fails under normal use as a result of a defect in material or workmanship. The decision to replace a complete product versus the part or component in question will be at BDI's sole discretion.

**Residential Use:** BDI Furnishings carry warranty coverage for three (3) years from the date of product delivery, as shown on your sales receipt/documentation. Select chairs carry coverage for five (5) years from the date of product delivery.

**Commercial Use:** BDI Furnishings carry warranty coverage for one (1) year from the date of product delivery, as shown on your sales receipt/documentation. Select chairs carry coverage for five (5) years from the date of the product delivery, based on an 8-hour daily use pattern.

BDI reserves the right to refine or update its warranty from time to time. See the complete and latest warranty document at [www.bdiusa.com/warranty](http://www.bdiusa.com/warranty).

## PRODUCT REGISTRATION

Registering your new BDI product allows us to send you important product updates, service information, and helpful hints related to your BDI products.

Register today, and you will be **entered to win free a BINK table** from BDI: [www.bdiusa.com/register](http://www.bdiusa.com/register)

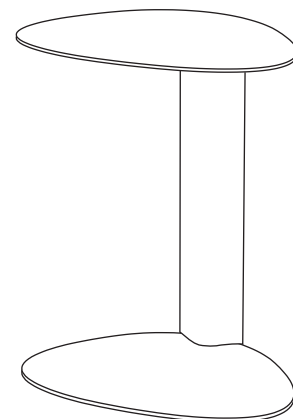



# WARNING

**SERIOUS OR FATAL CRUSHING INJURIES CAN OCCUR FROM FURNITURE TIP-OVER. TO HELP PREVENT TIP-OVER:**

- Install tip-over restraint.
- Place heaviest items in lower compartments.
- Never allow children to climb or hang on drawers, doors or shelves.
- Never open more than one drawer at a time.

**USE OF TIP-OVER RESTRAINT MAY REDUCE—BUT NOT ELIMINATE—THE RISK OF TIP-OVER.**



**BDIUSA.COM**

These distinctive product configurations are protected by US and international patents, trade dress, and/or copyright laws. Sequel Studio & BDI are trademarks of Becker Designed, Inc. All rights reserved. ©2025, BDI | V.12.18.2025

Made in Vietnam.