

EILEEN™ 5166

SHELVING

INSTRUCTION MANUAL

LET'S GET STARTED.

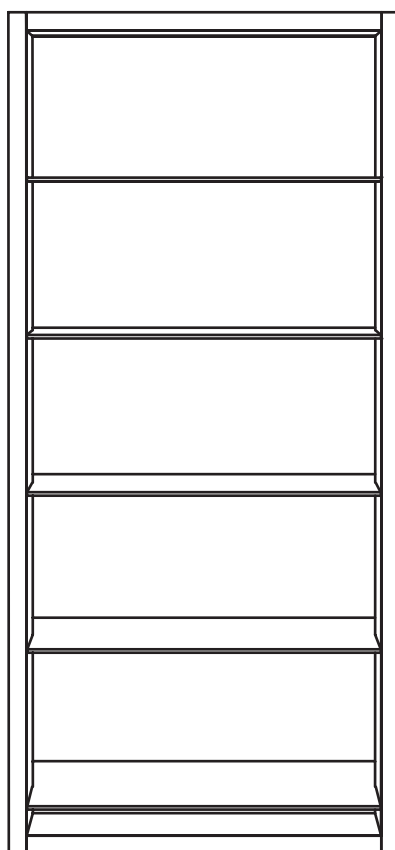

DESIGN MATTHEW WEATHERLY

BDi

BDIUSA.COM



Congratulations on the purchase of your Eileen Shelf from BDI. Your shelf has been designed to provide a lifetime of enjoyment. This manual will provide assembly instructions and other helpful information to ensure you get the most out of your product. Please save it for future reference.

Your Eileen Shelf has been engineered for simple assembly. Please follow these directions carefully to prevent any damage.

Should you need further assistance, contact BDI at customerservice@bdiusa.com.

ENJOY!

HARDWARE AND COMPONENTS

Unpack and identify the parts listed below. The assembly workspace should be a non-marring surface, such as carpet. For missing hardware pieces, please contact BDI Customer Service at customerservice@bdiusa.com. For all other concerns, please contact your BDI retailer.

Do not use power tools for the assembly of this product.



TOOL REQUIRED (NOT INCLUDED)

Phillips Screwdriver (T1)

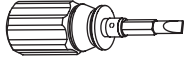

Flat Head Screwdriver (T2) QTY: 1



Cam Bolt (H1) QTY: 8



Wood Dowel (H2) QTY: 8

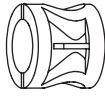

Barrel (H3) QTY: 8



Set Screw (H4) QTY: 8



Wood Screw (H5) QTY: 1

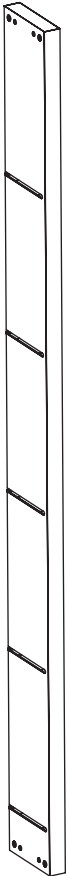

Right Side Panel (C1) QTY: 1

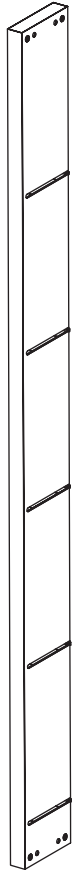

Left Side Panel (C2) QTY: 1

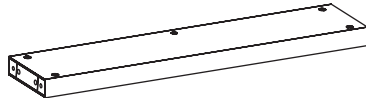

Top Panel (C3) QTY: 1

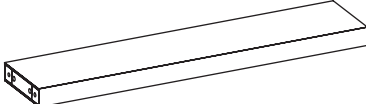

Bottom Panel (C4) QTY: 1

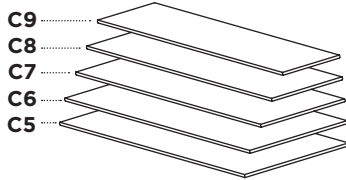

Glass Shelves (C5-C9) QTY: 1 of each

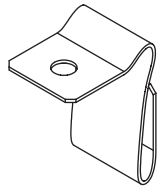



Safety Strap (C10) QTY: 1

STEP 1. INSTALL BOLTS AND DOWELS INTO PANELS

ASSEMBLY

Find the sets of 4 holes near the top and bottom edges of the **Side Panels (C1 & C2)**. Screw **8 Cam Bolts (H1)** into the threaded holes using **Phillips Head Screwdriver (T1) (not included)**.

Push **8 Wooden Dowels (H2)** into the inner holes on both ends of the **Top and Bottom Panels (C3 & C4)**.

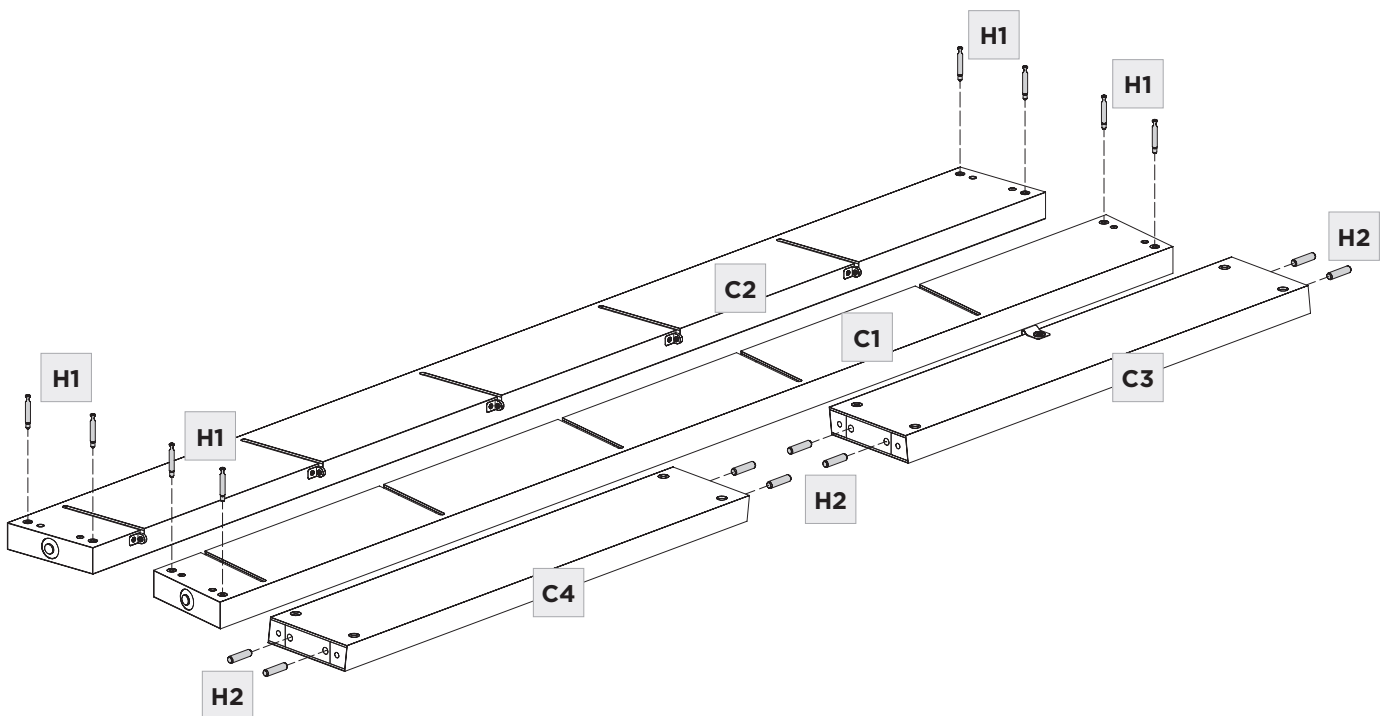

	NOT INCLUDED PHILLIPS SCREWDRIVER – T1	QTY 1
	CAM BOLT – H1	QTY 8
	WOOD DOWEL – H2	QTY 8



Insert **4 Barrels (H3)** into the holes on the top of the **Top Panel (C3)**, and **4 Barrels (H3)** into the holes on the bottom of the **Bottom Panel (C4)**. Make sure that the hole in the side of the Barrels is aligned with the holes in the end of the panels.

After the Barrels are installed, screw the **8 Set Screws (H4)** into the Barrels using the **Flat Head Screwdriver (T2)**. Do not turn more than 1-2 rotations.

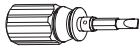
NOTE: Look into the side of the Barrel Nuts (H3) and make sure the Set Screw (H4) is not blocking the hole. If the hole is blocked, unscrew the set screw a few turns until the hole is clear, which will allow the cam bolts to enter.

	FLAT HEAD SCREWDRIVER – T2	QTY 1
	BARREL – H3	QTY 8
	SET SCREW – H4	QTY 8

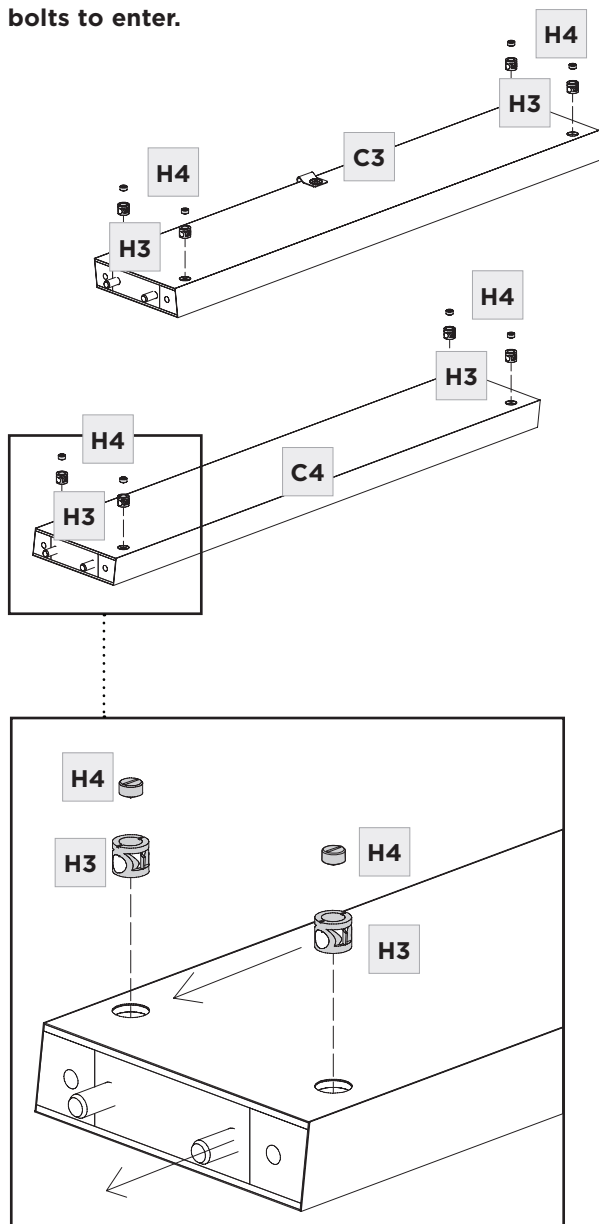

Hardware Combination

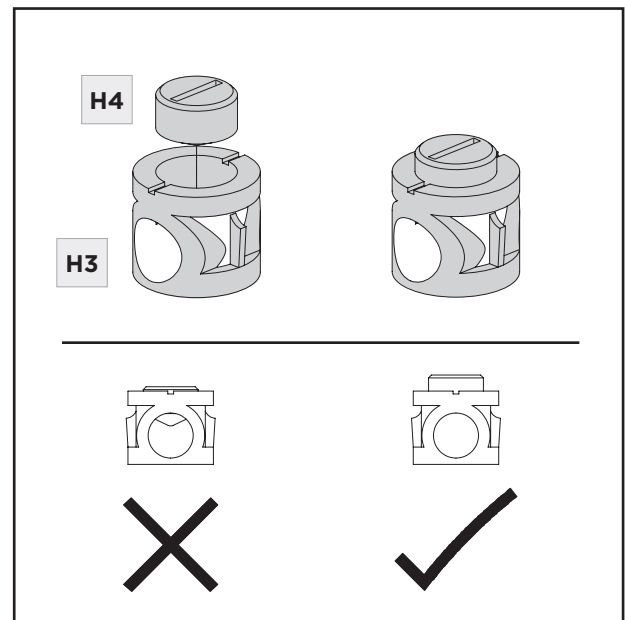

Hardware Orientation

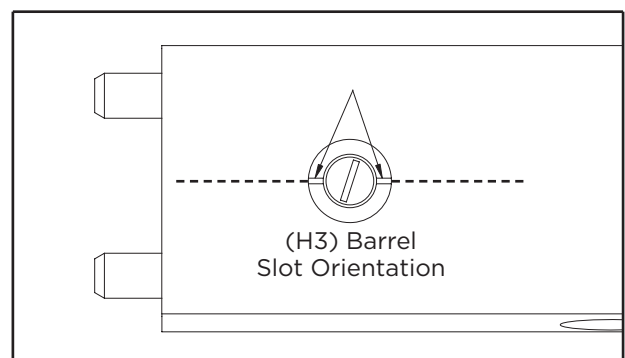

STEP 3. ATTACH TOP & BOTTOM PANELS TO SIDE PANELS

ASSEMBLY

Attach the **Top** and **Bottom Panels (C3 & C4)** to the **Side Panels (C1 & C2)** by sliding the dowels and cam bolts into the edge of the holes on the Top and Bottom Panels.

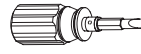

FLAT HEAD
SCREWDRIVER – T2

QTY
1

If cam bolts don't go into the barrel nuts, check to make sure the barrel nut is aligned with the side hole and make sure the set screw is loosened before insertion of the cam bolts. Orient the shelf as shown, ensuring the brackets on the back are facing up.

Tighten barrel nuts using **Flat Head Screwdriver (T2)** with a clockwise turn.

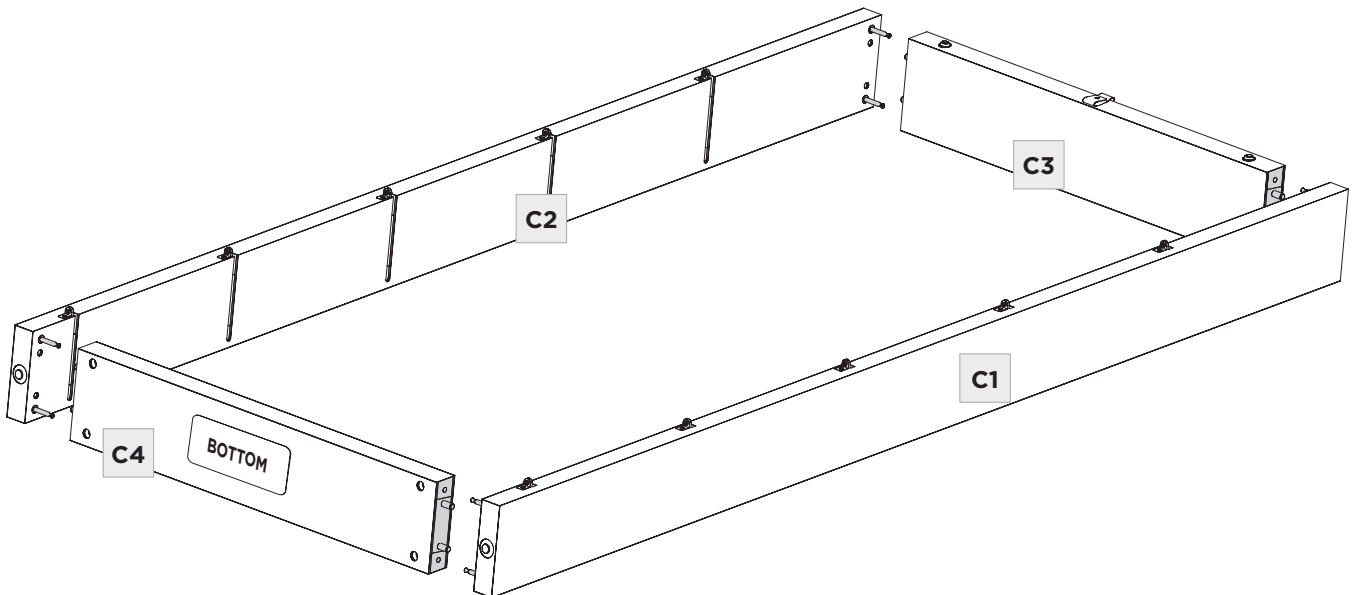

Install the **Glass Shelves (C5-C9)** in the slots in the Side Panels. Put the **Bottom Shelf (C5)** (the largest) in the bottom slot, and work your way up until the **Top Shelf (C9)** (the smallest) goes into the top slot.

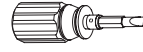

FLAT HEAD
SCREWDRIVER – T1

QTY
1

Tighten the set screw at the back of Side Panels until snug.
DO NOT OVERTIGHTEN, SCREW WILL STRIP.

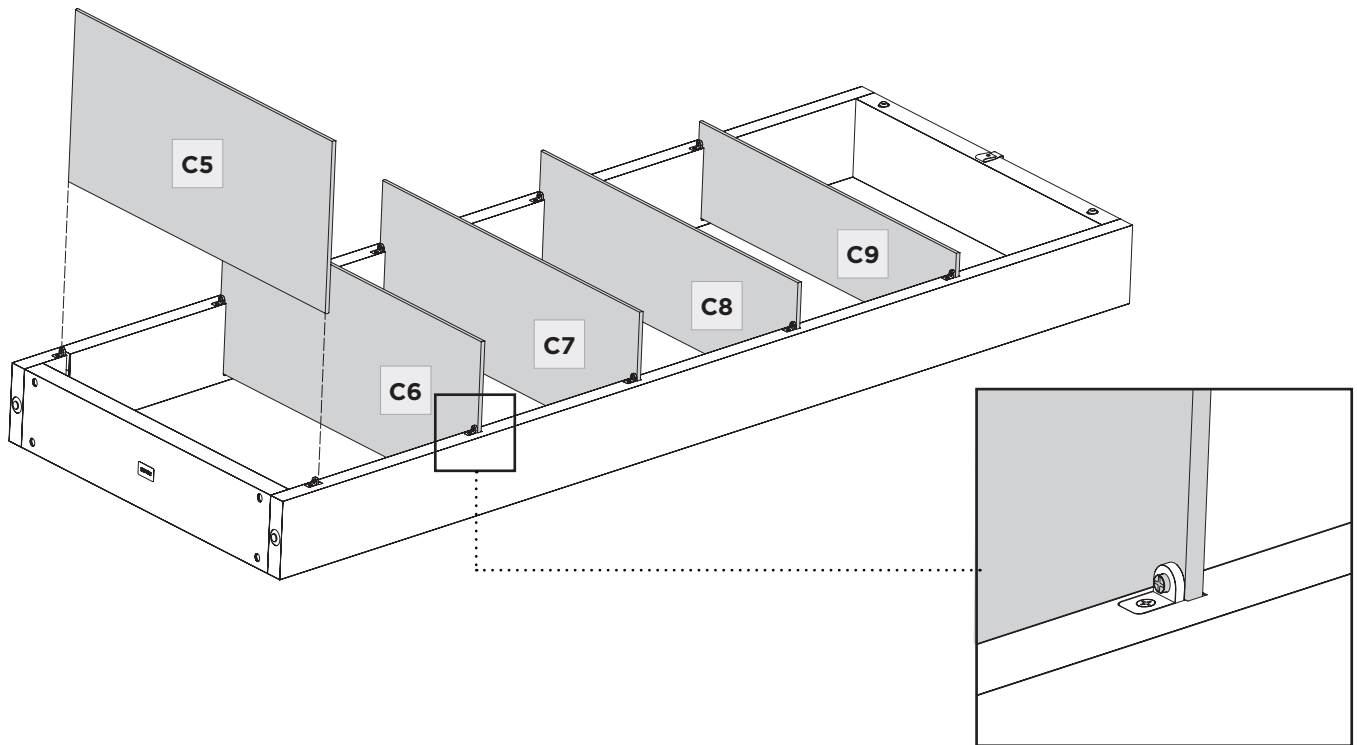

STEP 5. LIFT SHELF AGAINST THE WALL

ASSEMBLY

Lift the shelving assembly up against the wall. The rear edge of all shelves (except bottom shelf) should be approximately 1/8" from the wall.

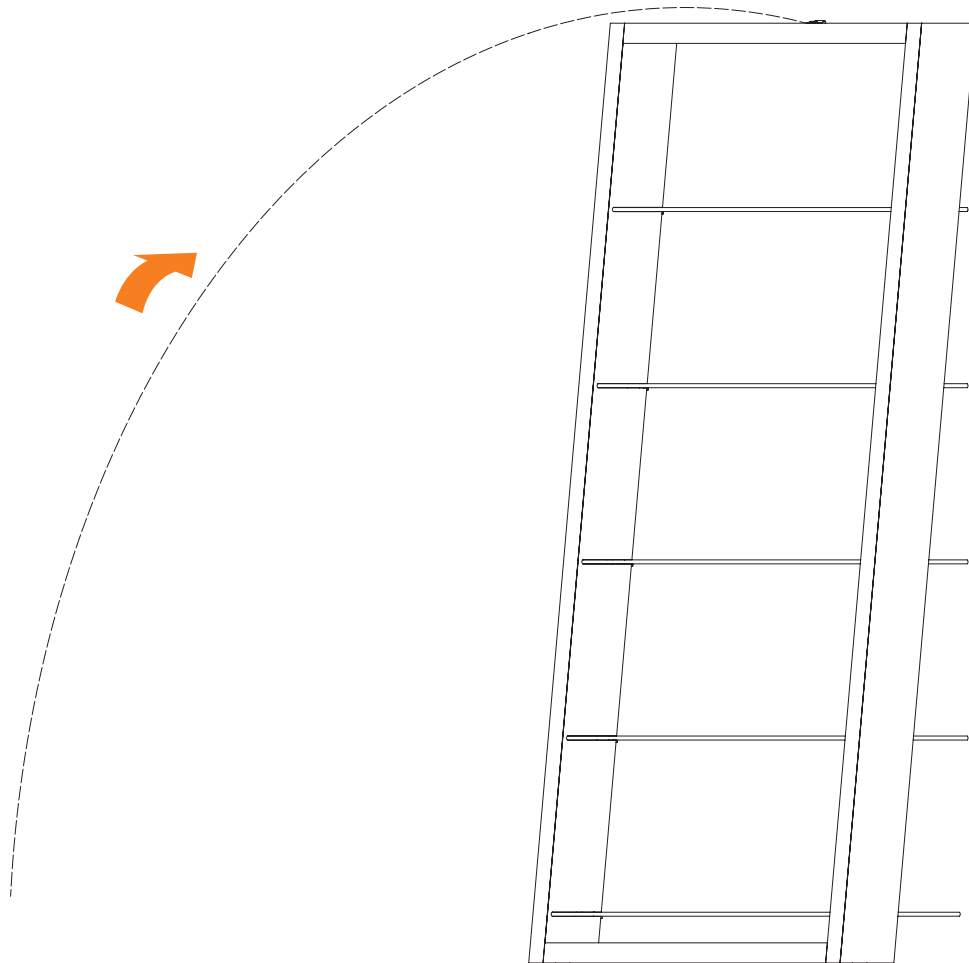

Stand the shelf against the wall in the desired location. Ensure that both wall levelers are touching the wall. Adhere a piece of painter's tape as the illustration depicts. Mark the wall **72.75 inches up from the floor, and 17.25 inches in from the edge** of the painter's tape. This mark will be the location of the wall anchor/fastener to secure your **Safety Strap (C10)** to the wall.

NOTE: This can be done on either side of the shelf.

Drill a hole at this location for wall insert. At the marked location, install the **appropriate Wall Anchor for your wall construction**. Attach the **Safety Strap (C10)** to the wall using the **Wood Screw (H5)**.

	SCREW – H5	QTY 1
---	------------	----------

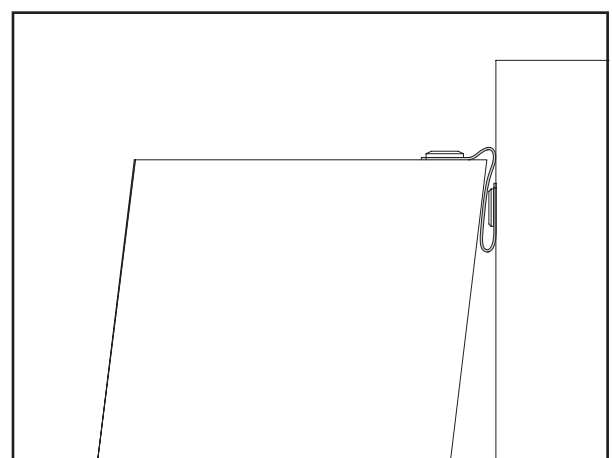
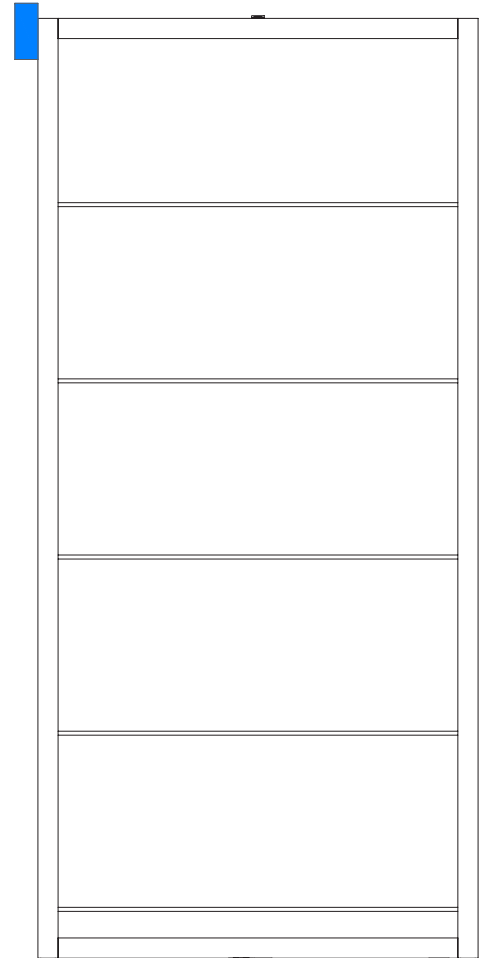
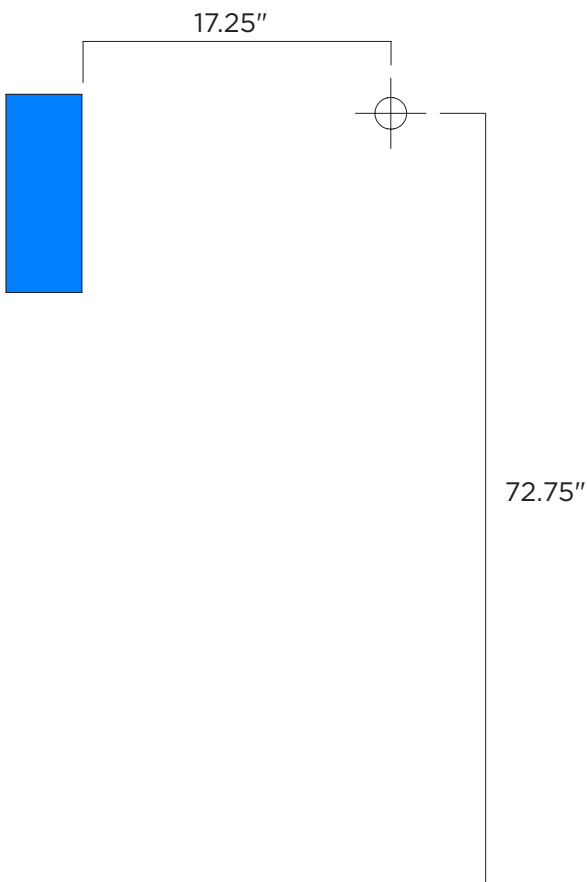

Safety Strap Detail Side View

Your BDI furniture has been constructed with the finest materials, carefully manufactured, and designed to last a lifetime. Regular furniture care will prolong your enjoyment and keep it looking its best. Here are some general tips for taking care of BDI furniture. Your surfaces may vary.

GLASS

Glass surfaces are maintained using household glass cleaner and a paper towel or cloth.

SATIN-ETCHED GLASS

This uniquely smooth-to-the-touch glass surface can be regularly maintained using household glass cleaner and a paper towel or cloth.

A 'Magic Eraser' removes minor scratches or scuffs not eliminated using a paper towel or cloth. 'Magic Eraser' is a melamine foam product available at any grocery store or home improvement center. Dampen the entire glass surface and the Magic Eraser, then rub the whole surface in broad, even strokes using moderate pressure. Clean and dry the surface with a paper towel. Check for results and repeat as necessary. Any scratches or scuffing not eliminated by one of the above methods can often be addressed by 'refreshing' the glass. This process should not be required more than once per 6-12 months. See this brief video for the simple method: www.bdiusa.com/glass

WOOD

Wood surfaces should be cleaned with a slightly damp (not saturated) cloth or paper towel. Do not use glass cleaner on wood. If moisture remains, dry the surface with another cloth. If needed, a gentle, non-abrasive cleanser may be used, but wipe away all cleaner residue and dry the surface with a cloth.

BDI's wood finishes feature natural hardwood solids and veneers. Wood is a product of nature and—unlike man-made materials that can be manufactured to strict and consistent specifications—has natural imperfections that are part of its appeal and character. Every piece of wood differs from every other, even when coming from the very same tree. As such, grain, texture, and tone variation should be expected from one panel or piece of furniture to the next.

While BDI's stained wood finishes are stable in tone & appearance, all finishes are subject to some degree of discoloration with prolonged exposure to direct sunlight. Please avoid positioning your BDI cabinet in any area with ample direct sunlight. To learn more about the features of natural wood, visit www.bdiusa.com/wood

METAL, PORCELAIN, & PAINTED SURFACES

Surfaces should be cleaned with a slightly damp (not saturated) cloth or paper towel. If moisture remains, dry the surface with another cloth. If needed, a gentle, non-abrasive cleanser may be used, but be sure to wipe away all cleaner residue and dry the surface with a cloth.

WARRANTY

BDI warrants to the original purchaser that for the below-stated warranty term, BDI will replace any product, part, or component covered by this warranty that fails under normal use as a result of a defect in material or workmanship. The decision to replace a complete product versus the part or component in question will be at BDI's sole discretion.

Residential Use: BDI Furnishings carry warranty coverage for three (3) years from the date of product delivery, as shown on your sales receipt/documentation. Select chairs carry coverage for five (5) years from the date of product delivery.

Commercial Use: BDI Furnishings carry warranty coverage for one (1) year from the date of product delivery, as shown on your sales receipt/documentation. Select chairs carry coverage for five (5) years from the date of the product delivery, based on an 8-hour daily use pattern.

BDI reserves the right to refine or update its warranty from time to time. See the complete and latest warranty document at www.bdiusa.com/warranty.

PRODUCT REGISTRATION

Registering your new BDI product allows us to send you important product updates, service information, and helpful hints related to your BDI products. Register today, and you will be entered to win free a BINK table from BDI: www.bdiusa.com/register



WARNING

SERIOUS OR FATAL CRUSHING INJURIES CAN OCCUR FROM FURNITURE TIP-OVER. TO HELP PREVENT TIP-OVER:

- Install tip-over restraint.
- Place heaviest items in lower compartments.
- Never allow children to climb or hang on drawers, doors, or shelves.
- Never open more than one drawer at a time.

USE OF TIP-OVER RESTRAINT MAY REDUCE—BUT NOT ELIMINATE—THE RISK OF TIP-OVER.



BDIUSA.COM

These distinctive product configurations are protected by US and international patents, trade dress, and/or copyright laws. Eileen & BDI are trademarks of Becker Designed, Inc. All rights reserved. ©2023, BDI | V.08.10.2023

Made in Turkey.