

ARENA BOND ARENA LONG BOND

design Yasuhiro Shito - 2020 / 2022

cattelan
italia

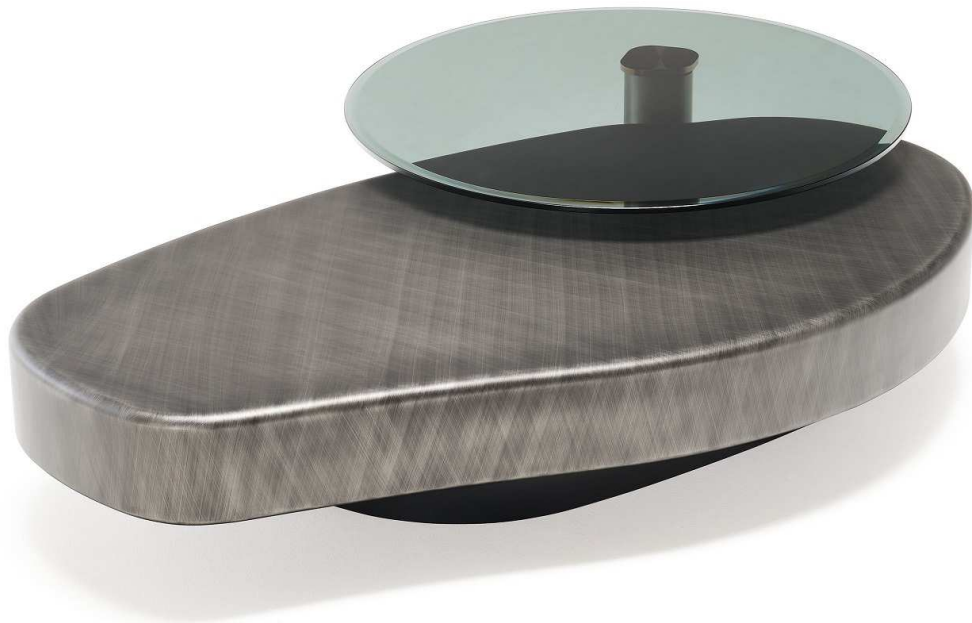
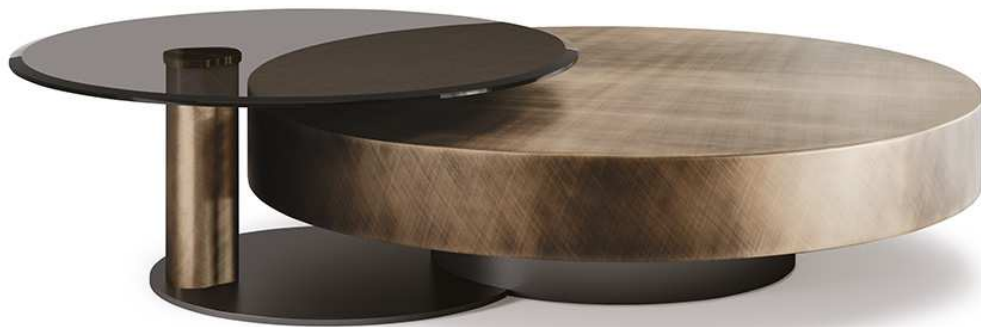

ISTRUZIONI DI MONTAGGIO - ASSEMBLING INSTRUCTIONS - MONTAGEANLEITUNG
INSTRUCTIONS DE MONTAGE - INSTRUCCIONES DE MONTAJE
ИНСТРУКЦИИ ПО МОНТАЖУ - 安装指导 - تعليمات التجميع

Cattelan Italia spa si riserva di apportare, senza preavviso, modifiche nei materiali, nei rivestimenti, nelle finiture e nei disegni dei prodotti. Le textures ed i colori dei materiali e delle finiture hanno valore indicativo in quanto soggetti alle tolleranze dei processi di stampa.

Cattelan Italia spa reserves the right to change, without previous notice, materials, covers, finishes and drawings of the products. The textures and colours of materials and finishes are indicative as they are depending on the tolerances of the printing process.

Cattelan Italia spa behaltet sich vor, ohne Vorankündigung, Veränderungen an den Materialien, Bezügen, Finish und Zeichnungen Produkte vorzunehmen. Die Texturen und Farben der Materialien und Finish haben einen hinweisenden Wert, da sie von den Toleranzen im Druckprozess abhängig sind.

Cattelan Italia spa se réserve le droit d'apporter, sans préavis, des modification au niveau des matériaux, des revêtements, des finitions et du design des produits. Les textures et les couleurs des matériaux et des finitions sont une valeurs indicative parce-que ils changent selon la tolérance aux procédés d'imprimerie.

Cattelan Italia spa se reserva el derecho de aportar modificaciones de dibujo, materiales, acabados y tapicerias, sin que esté obligada a dar aviso antipado. Las textures y los colores de los materiales y de los acabados tienen solo un valor indicativo porque estan sujetos a la tolerancia en los procesos de imprenta.

Cattelan Italia spa оставляет за собой право делать изменения, без предупреждения, в материалах, обивках, отделках и в чертежах продуктов, которые представлены в данном каталоге. Текстуры и цвета материалов и отделок в каталоге не передают реальные цвета предметов, из-за особенности процессов печати и цветопередачи.

Cattelan Italia

公司保留变更图册中材料、包覆材质、饰面、图像的权利，无须事先通知。因印刷等工艺存在偏差，材料和饰面等的纹理和颜色仅供参考。

تحتفظ شركة Cattelan Italia SPA بالحق في تغيير المواد والأغطية والتشطيبات والرسومات الخاصة بالمنتجات دون إشعار مسبق.
تعتبر قوام وألوان المواد والتشطيبات إرشادية لأنها تعتمد على تفاوتات عملية الطباعة.

IMPORTANT: Riporre per eventuali consultazioni future.

IMPORTANT: File for future consultation.

WICHTIG: Bitte aufbewahren für eventuelle spätere Nachfragen.

IMPORTANT: A conserver pour les futurs besoins de reference.

IMPORTANTE: Guardar para consultas posteriores.

ВАЖНО: Сохранить для возможной будущей консультации.

重要事项：存档以备日后咨询

هام: ملف للتشاور في المستقبل.

ARENA BOND / DUBLE BOND

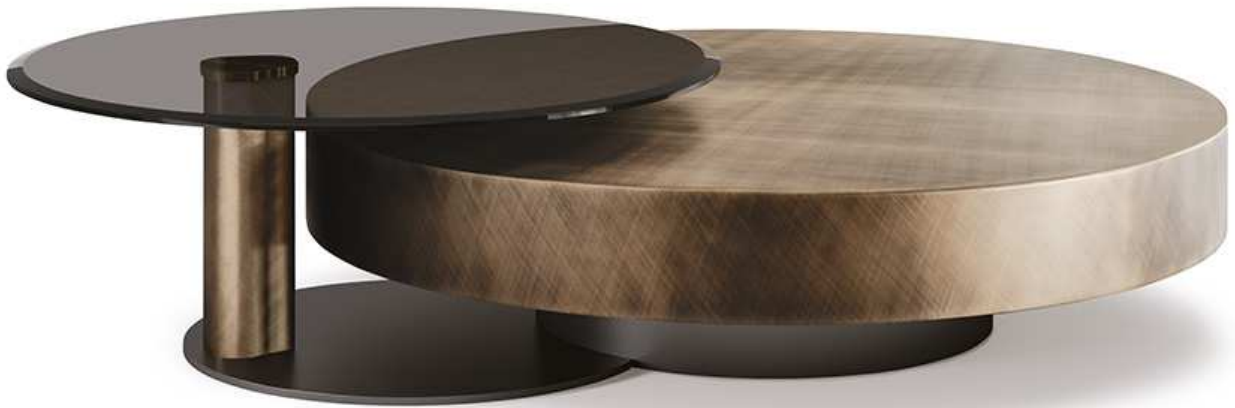

n° 04 TBCE M6x25 N.

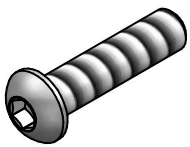

n° 03 TPSCE M8x25 ZB.

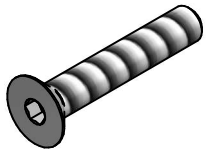

n° 04 ø6x18 N.

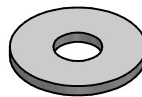

n° 01 da 04.

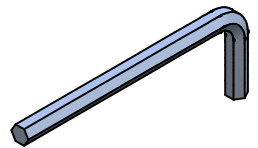

n° 02 TBCE M6x16 ZB



n° 03 TPSCE M6x12 ZB.



n° 02 ø6x18 ZB

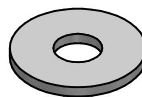

n° 01 da 05.

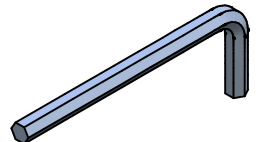

1

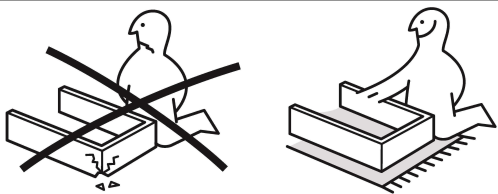

IMPORTANTE! - VERY IMPORTANT!
WICHTIG! - TRÈS IMPORTANT!
¡MUY IMPORTANTE! - ВАЖНО - 警告



Attenzione: non sedersi.
Attention: please do not sit.
Achtung: nicht hinsetzen.
Attention: ne pass'asseoir sur les tables.

Atención: no sentarse.
ВНИМАНИЕ: НЕ САДИТЬСЯ.

注意：请勿坐在上面。

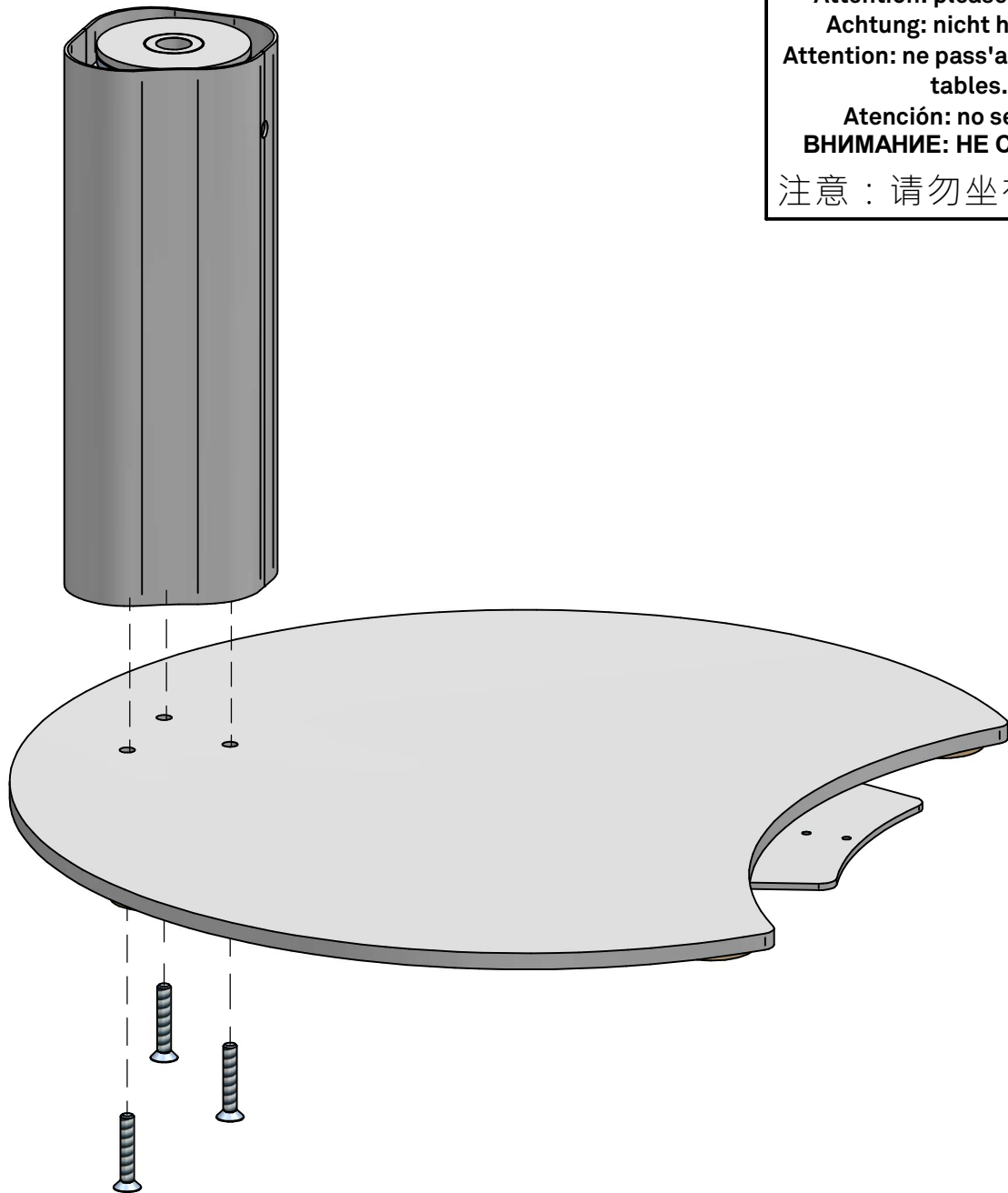

n° 03 TPSCE M8x25 ZB.

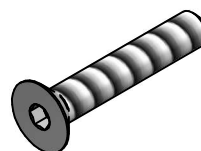

n° 01 da 05.

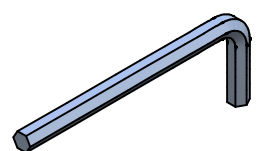

2

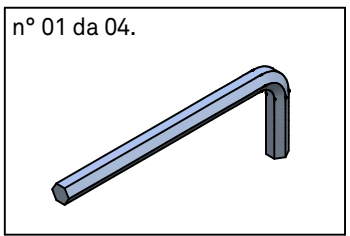
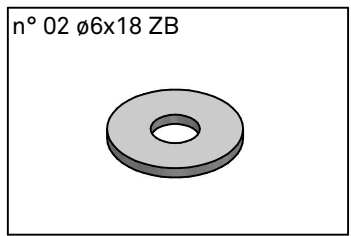
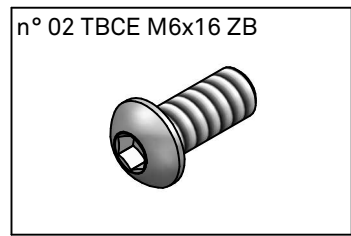
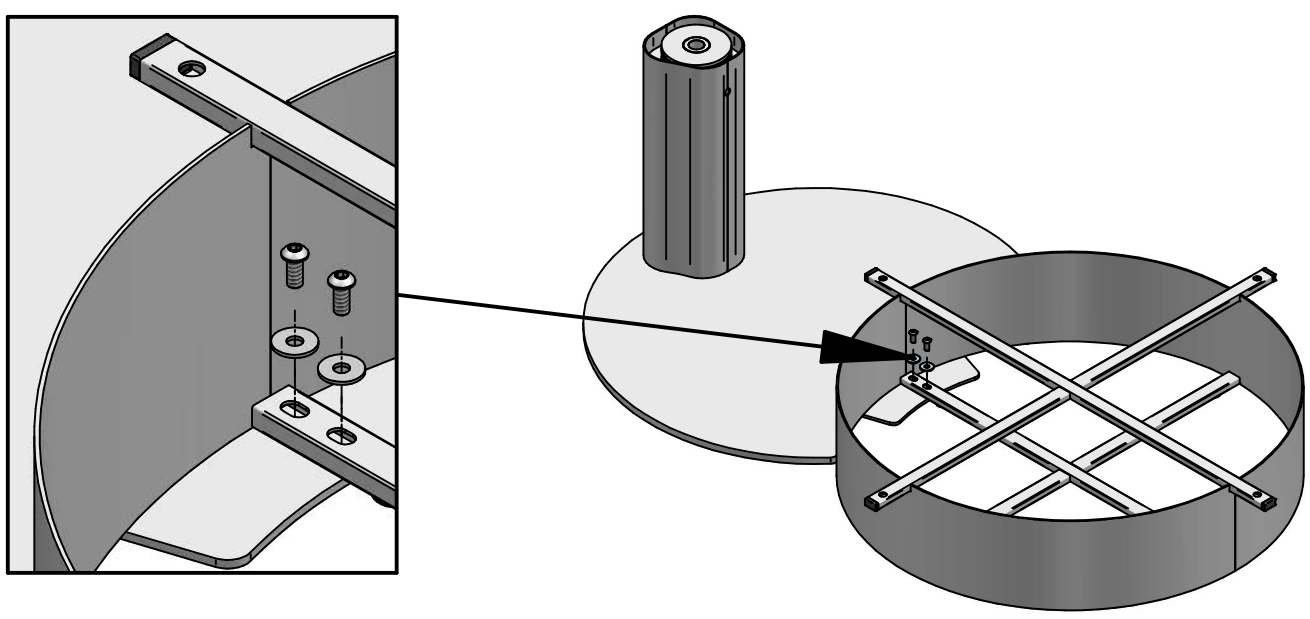
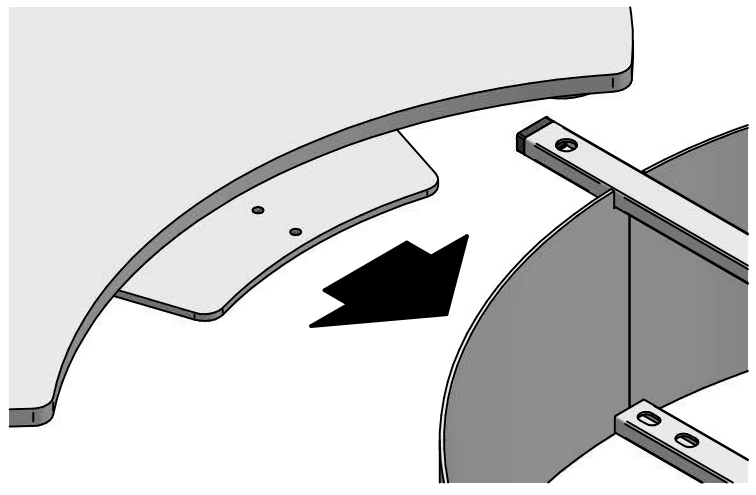
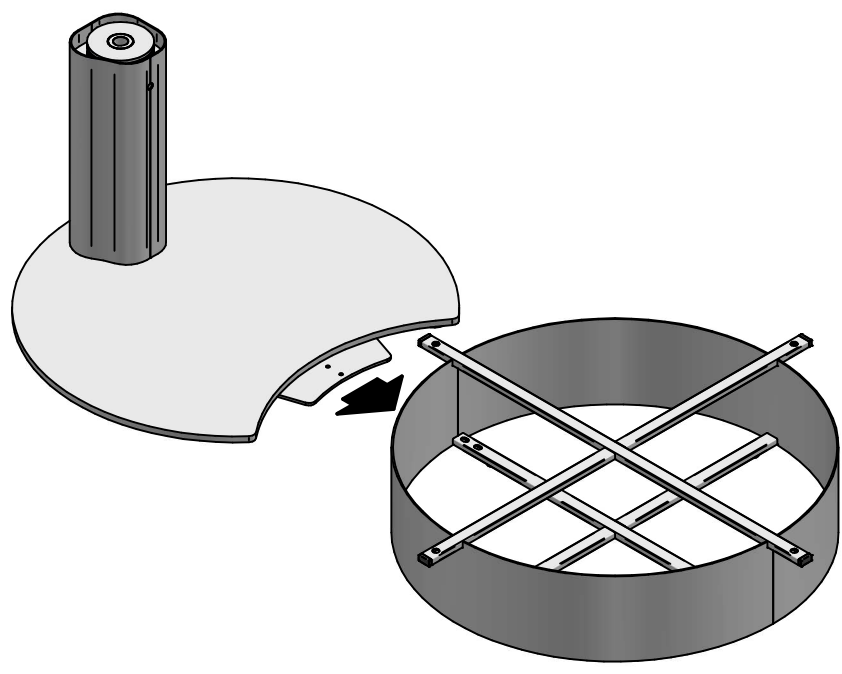

3 ESSENZIALE
 ESSENTIAL
 NOTWENDIG
 ESSENTIEL
 ¡ESENCIAL!
 ВАЖНО
 重要

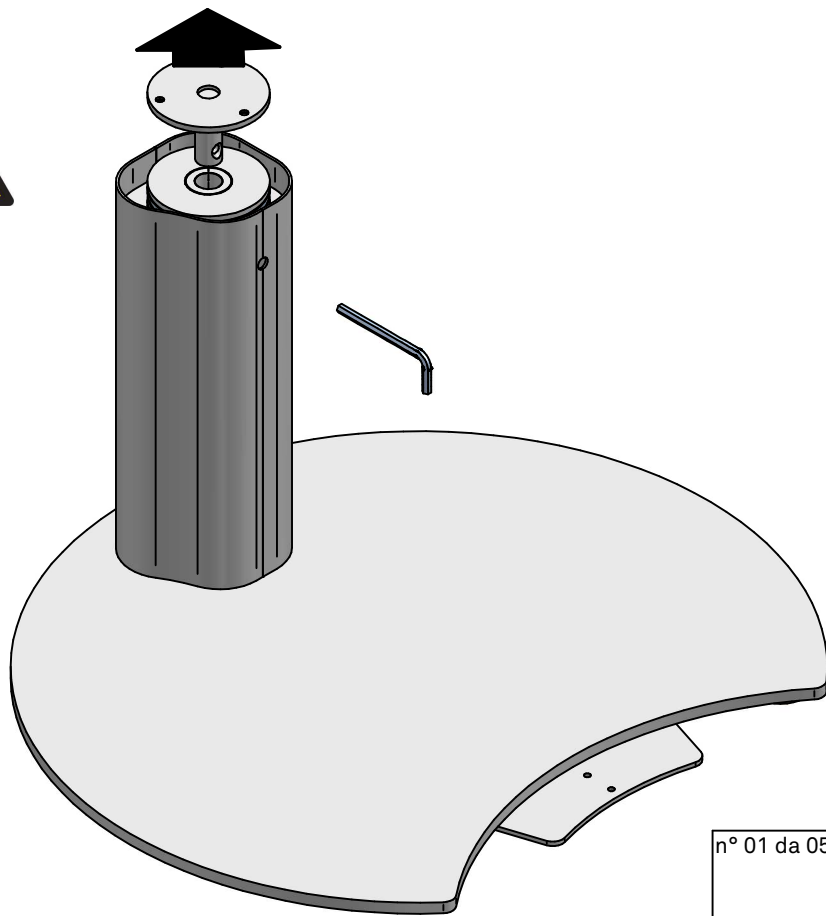

n° 01 da 05.

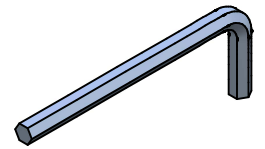

4

GLASS



IMPORTANTE!
 VERY IMPORTANT!
 WICHTIG!
 TRÈS IMPORTANT!
 ¡MUY IMPORTANTE!
 ВАЖНО
 警告

ATTENZIONE!
 ATTENTION!
 ACHTUNG!
 ATTENTION!
 ¡ATENCIÓN!
 ВНИМАНИЕ
 注意

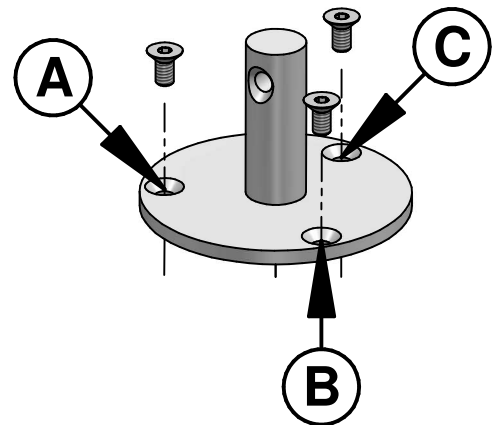
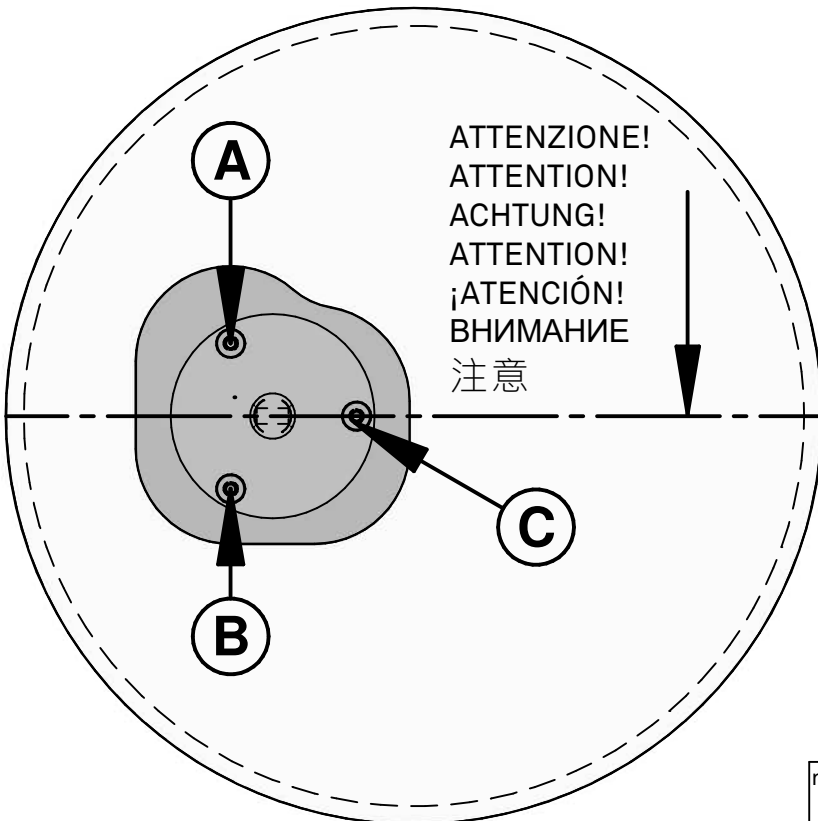

n° 03 TPSCE M6x12 ZB.



n° 01 da 04.

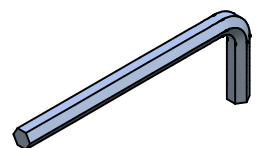

5 GLASS

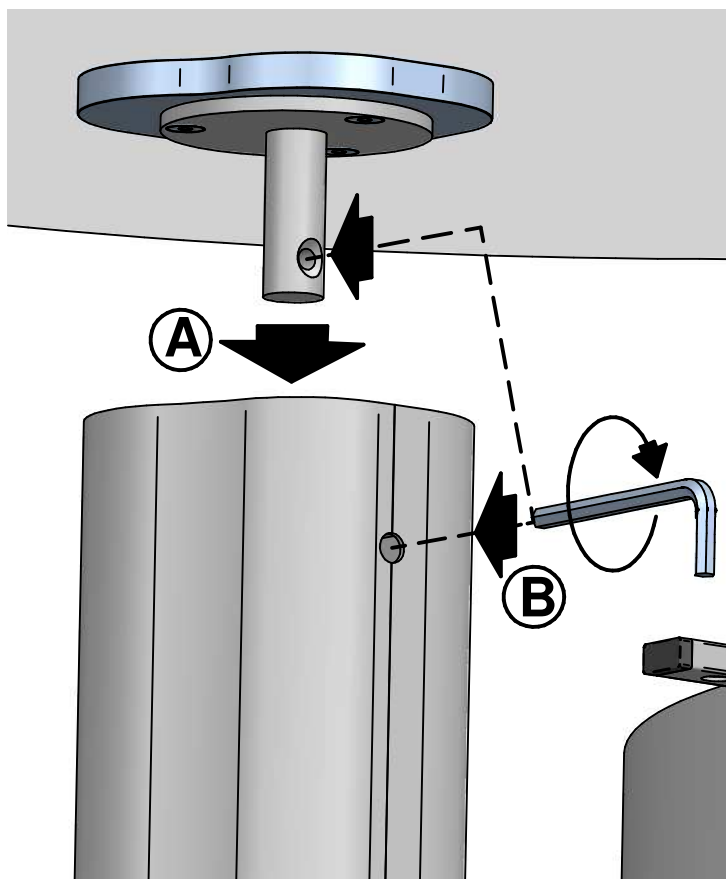
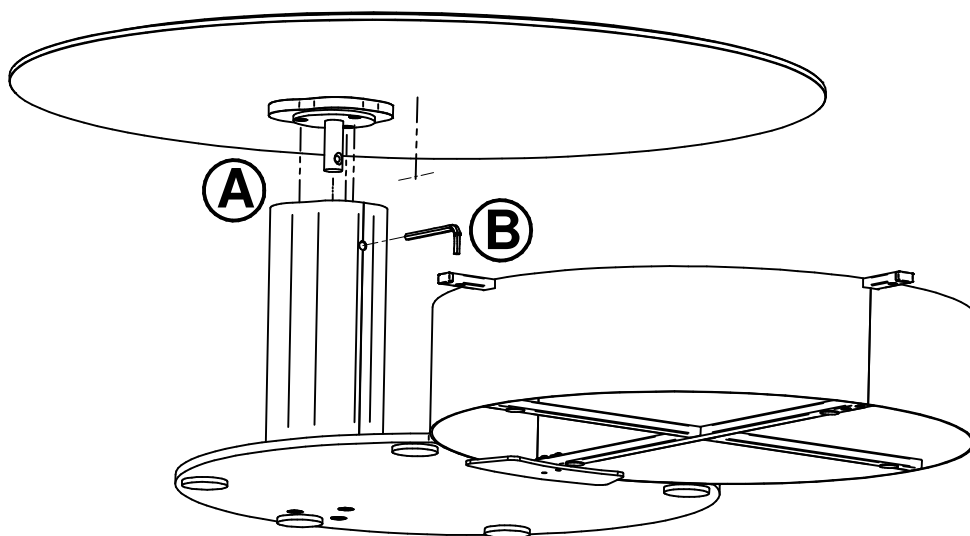
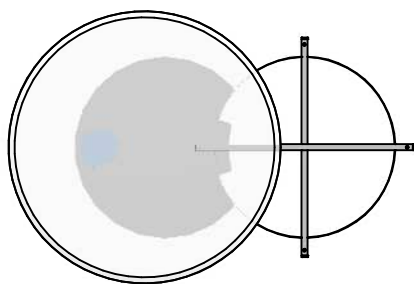

n° 01 da 05.

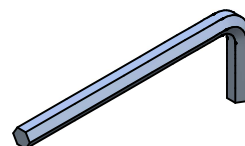

⑥ GLASS

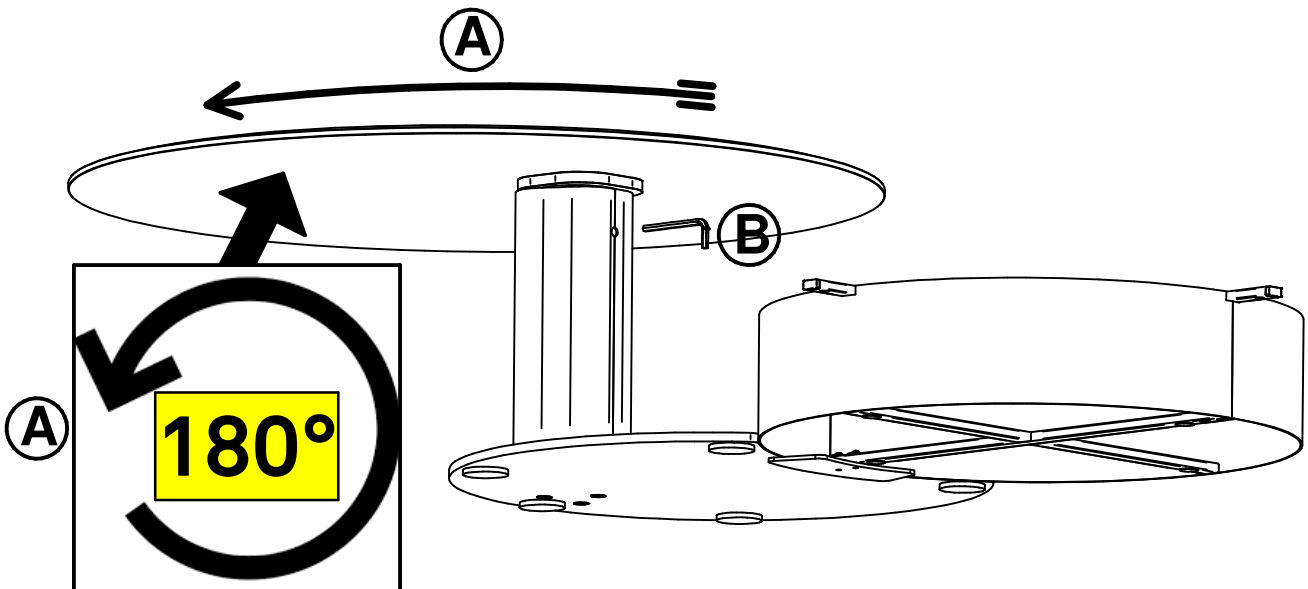
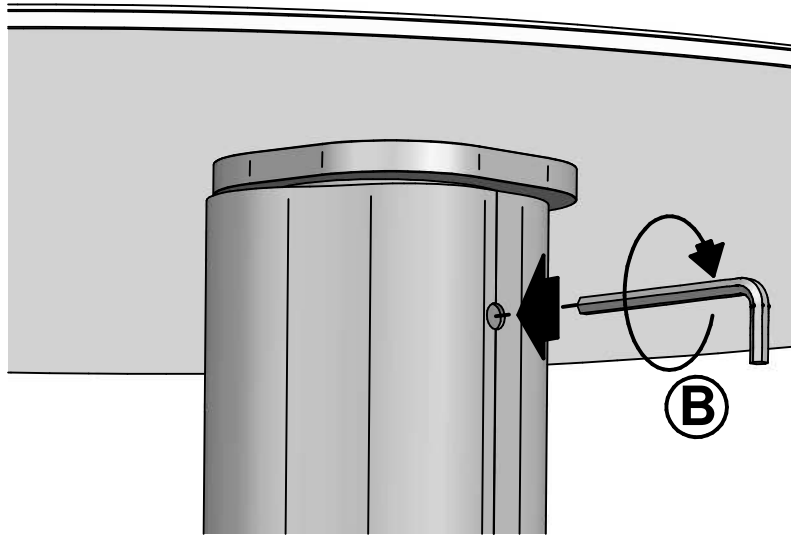
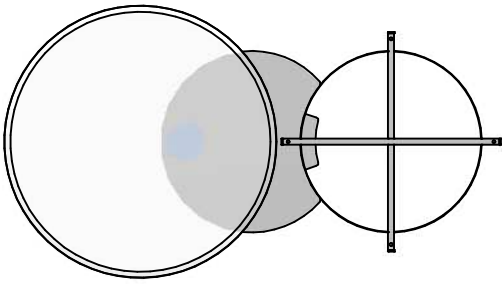

IMPORTANTE!
VERY IMPORTANT!
WICHTIG!
TRÈS IMPORTANT!
¡MUY IMPORTANTE!
ВАЖНО
警告

n° 01 da 05.

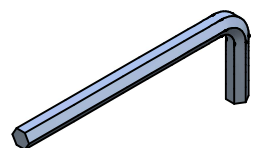

7

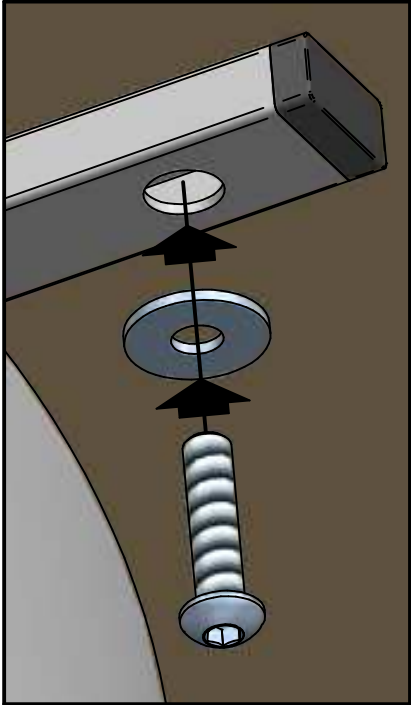
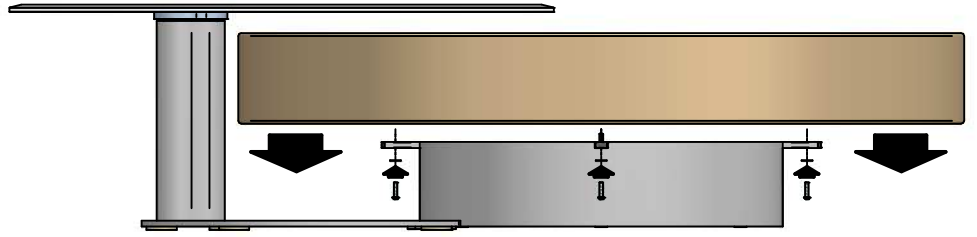

n° 04 TBCE M6x25 N.

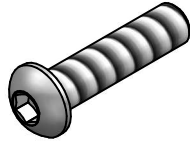

n° 04 ø6x18 N.

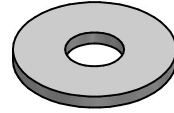

n° 01 da 04.

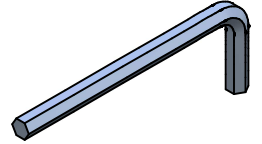

ARENA LONG BOND / DUBLE BOND

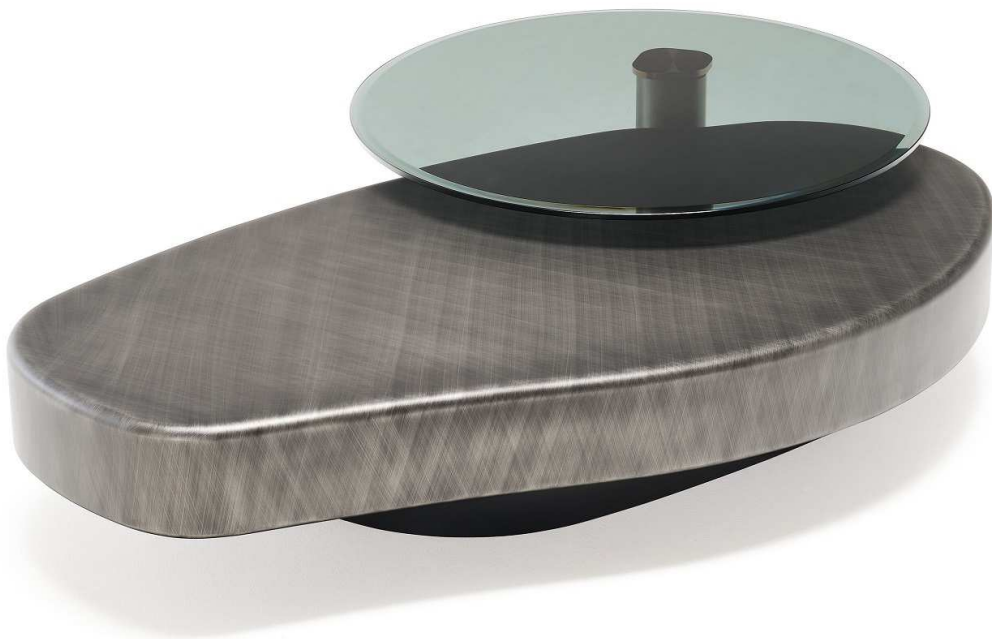

n° 04 TBCE M6x25 N.

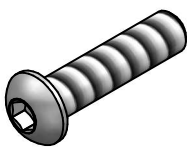

n° 03 TPSCE M8x25 ZB.

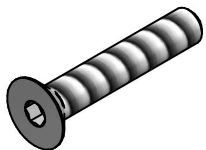

n° 04 ø6x18 N.

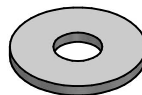

n° 01 da 04.

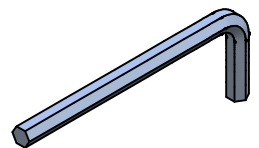

n° 02 TBCE M6x16 ZB

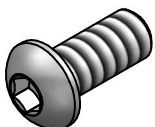

n° 03 TPSCE M6x12 ZB.



n° 02 ø6x18 ZB

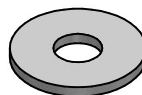

n° 01 da 05.

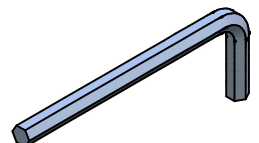

1

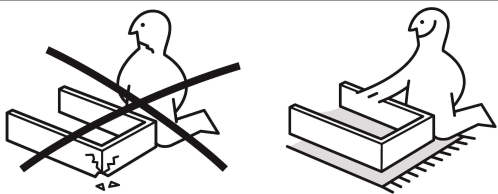

IMPORTANTE! - VERY IMPORTANT!
WICHTIG! - TRÈS IMPORTANT!
¡MUY IMPORTANTE! - ВАЖНО - 警告



Attenzione: non sedersi.
Attention: please do not sit.
Achtung: nicht hinsetzen.
Attention: ne pass'asseoir sur les tables.

Atención: no sentarse.
ВНИМАНИЕ: НЕ САДИТЬСЯ.

注意：请勿坐在上面。

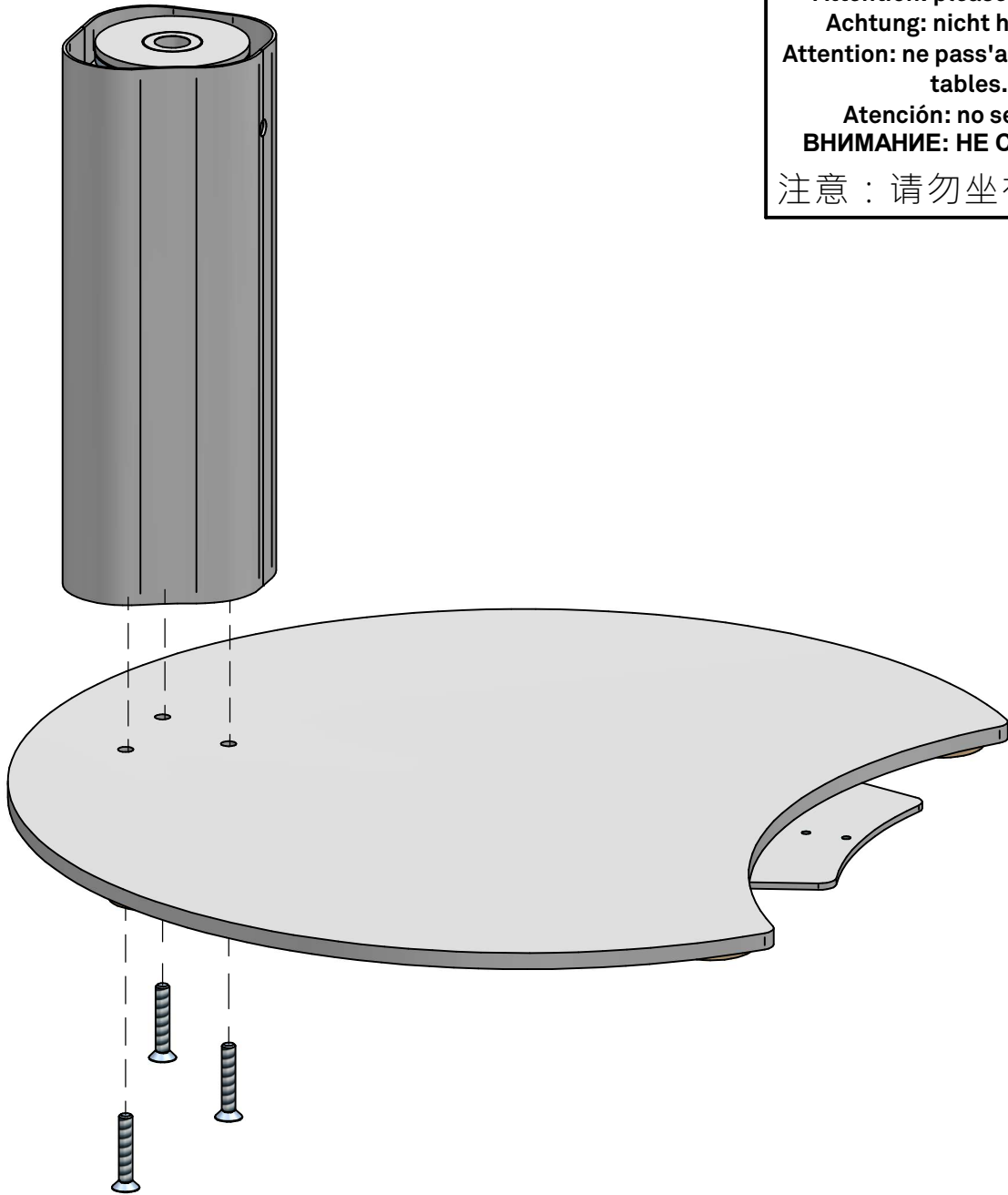

n° 03 TPSCE M8x25 ZB.

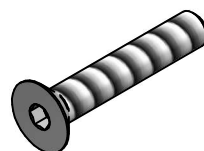

n° 01 da 05.

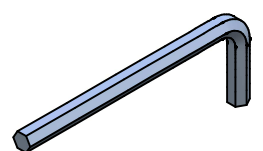

2

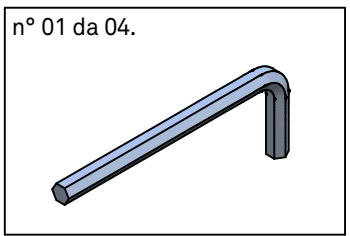
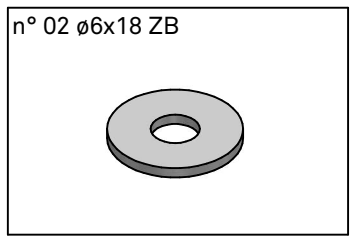
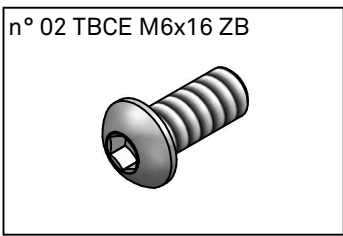
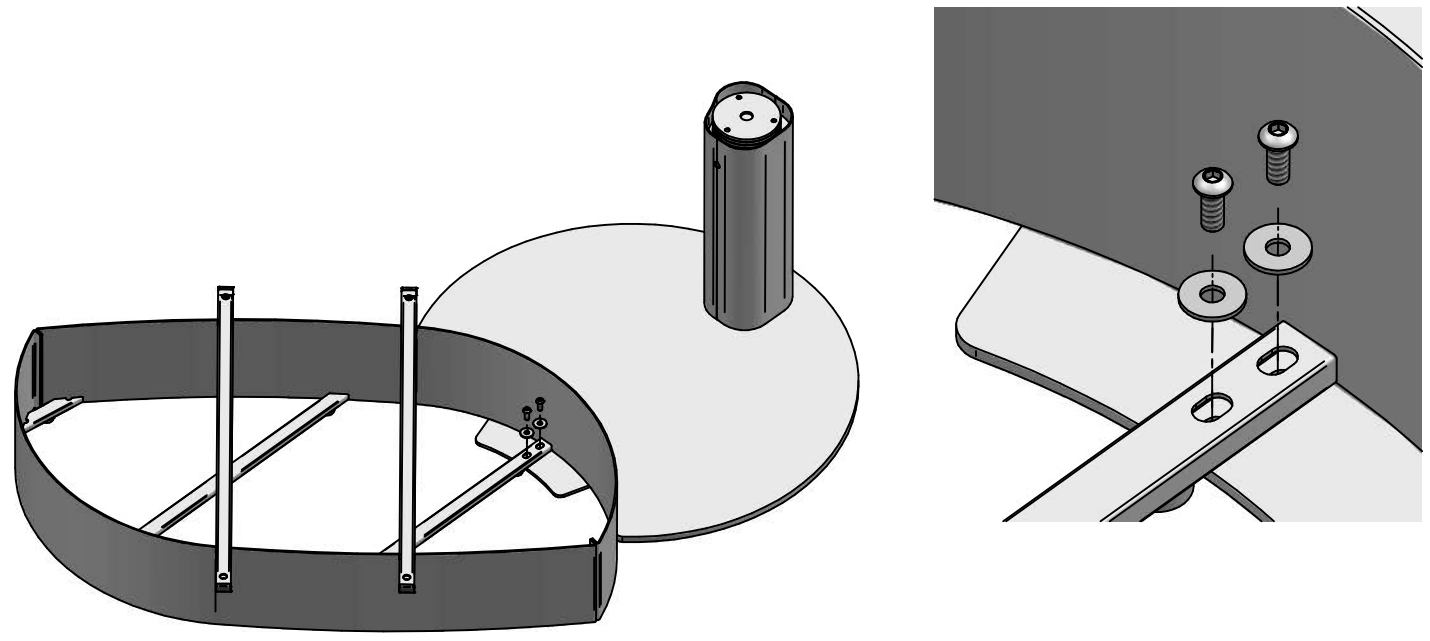
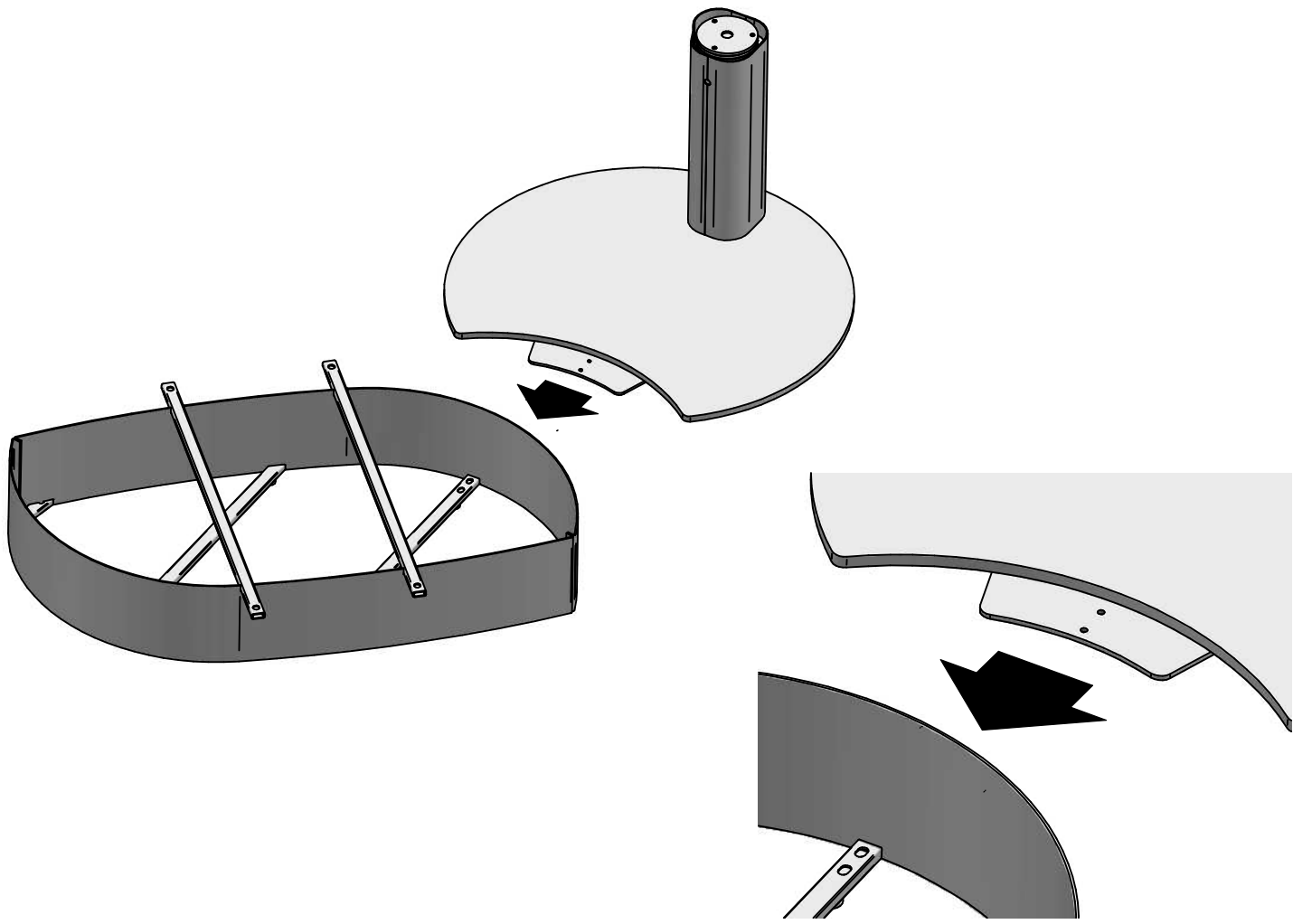

3 ESSENZIALE
 ESSENTIAL
 NOTWENDIG
 ESSENTIEL
 ¡ESENCIAL!
 ВАЖНО
 重要

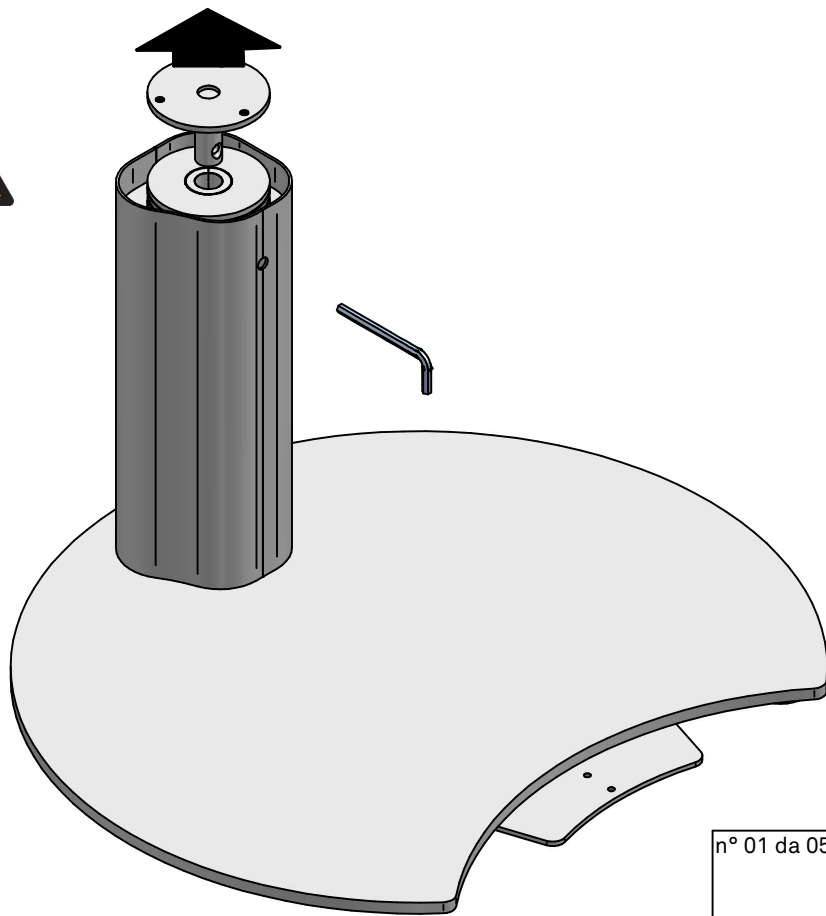

n° 01 da 05.

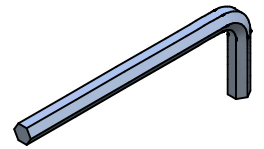

4

GLASS



IMPORTANTE!
 VERY IMPORTANT!
 WICHTIG!
 TRÈS IMPORTANT!
 ¡MUY IMPORTANTE!
 ВАЖНО
 警告

ATTENZIONE!
 ATTENTION!
 ACHTUNG!
 ATTENTION!
 ¡ATENCIÓN!
 ВНИМАНИЕ
 注意

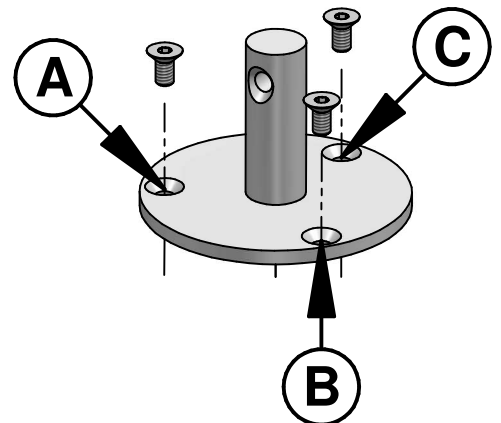
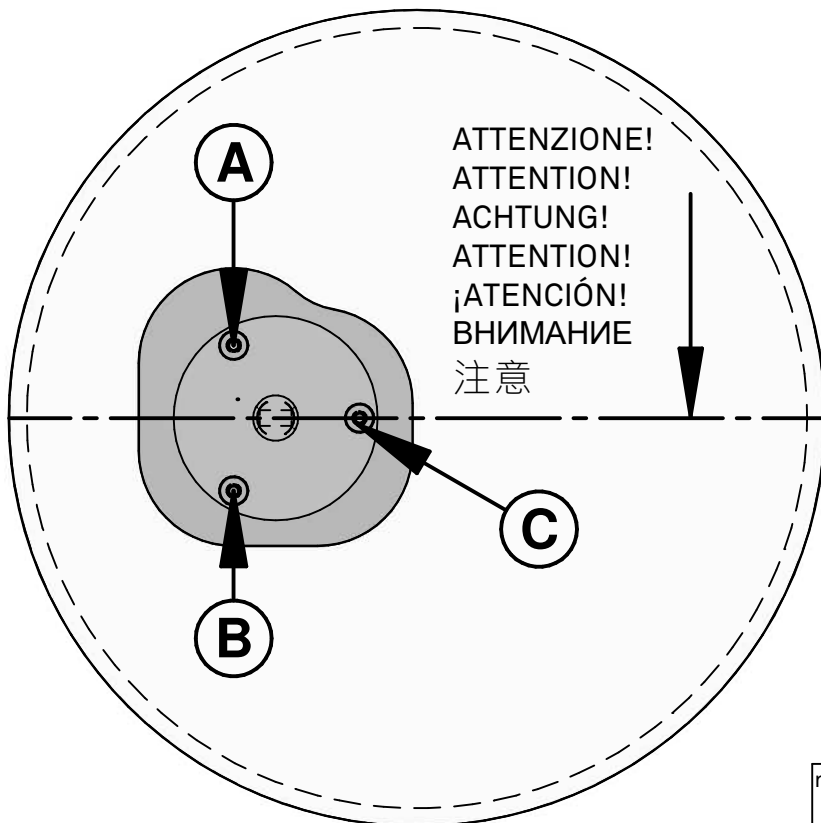

n° 03 TPSCE M6x12 ZB.

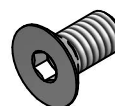

n° 01 da 04.

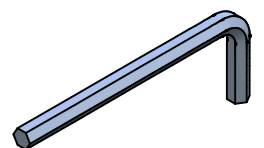

5 GLASS

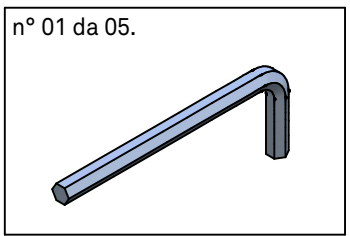
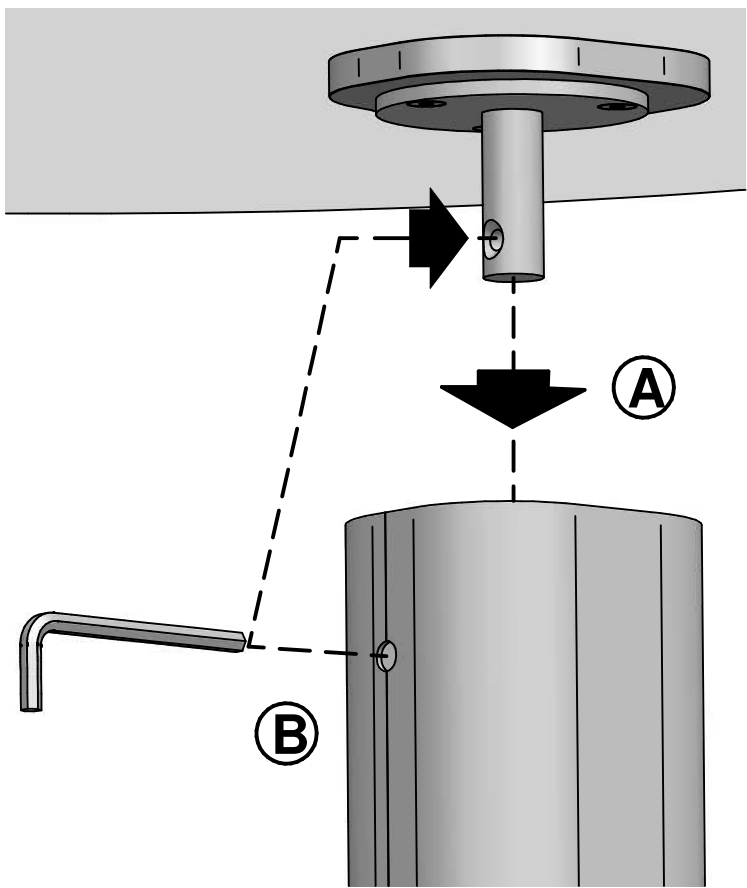
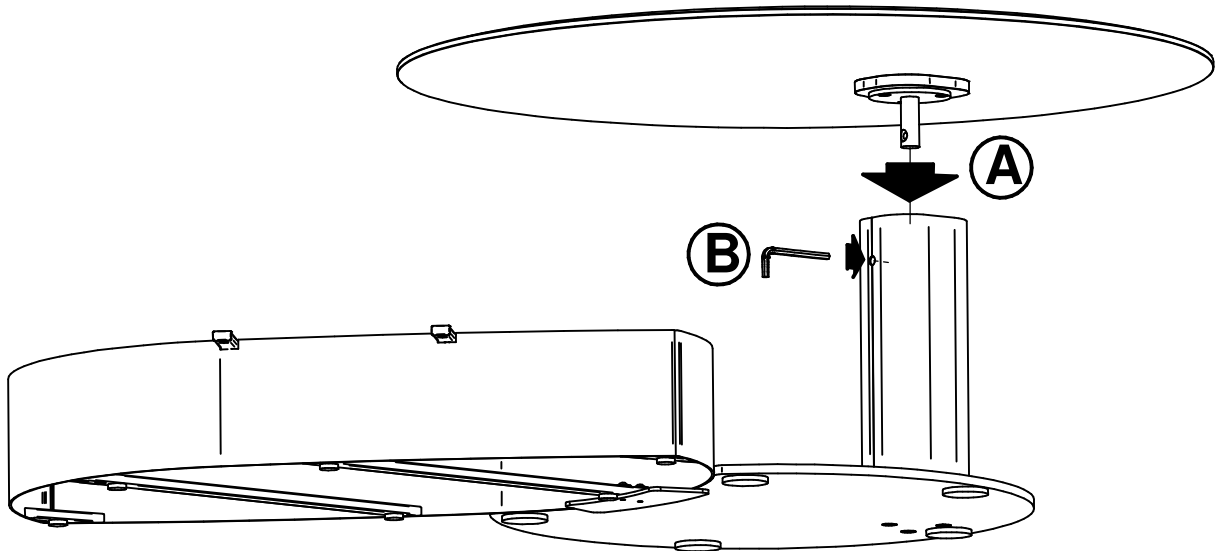
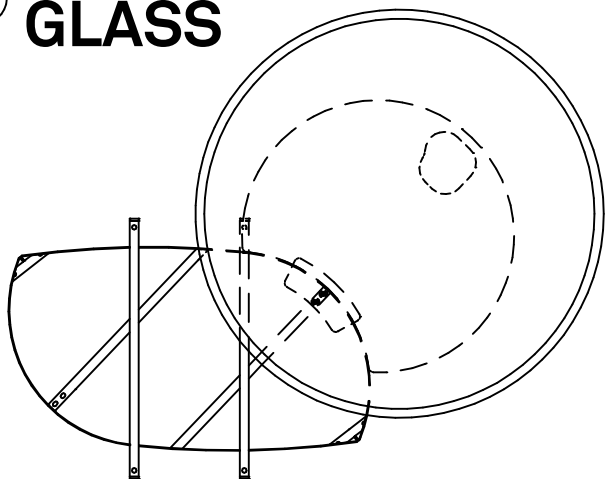

6 GLASS

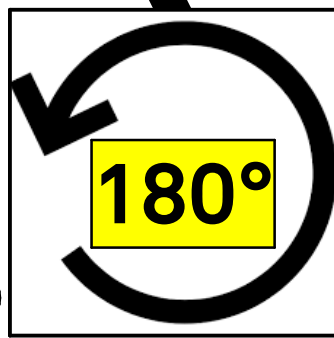
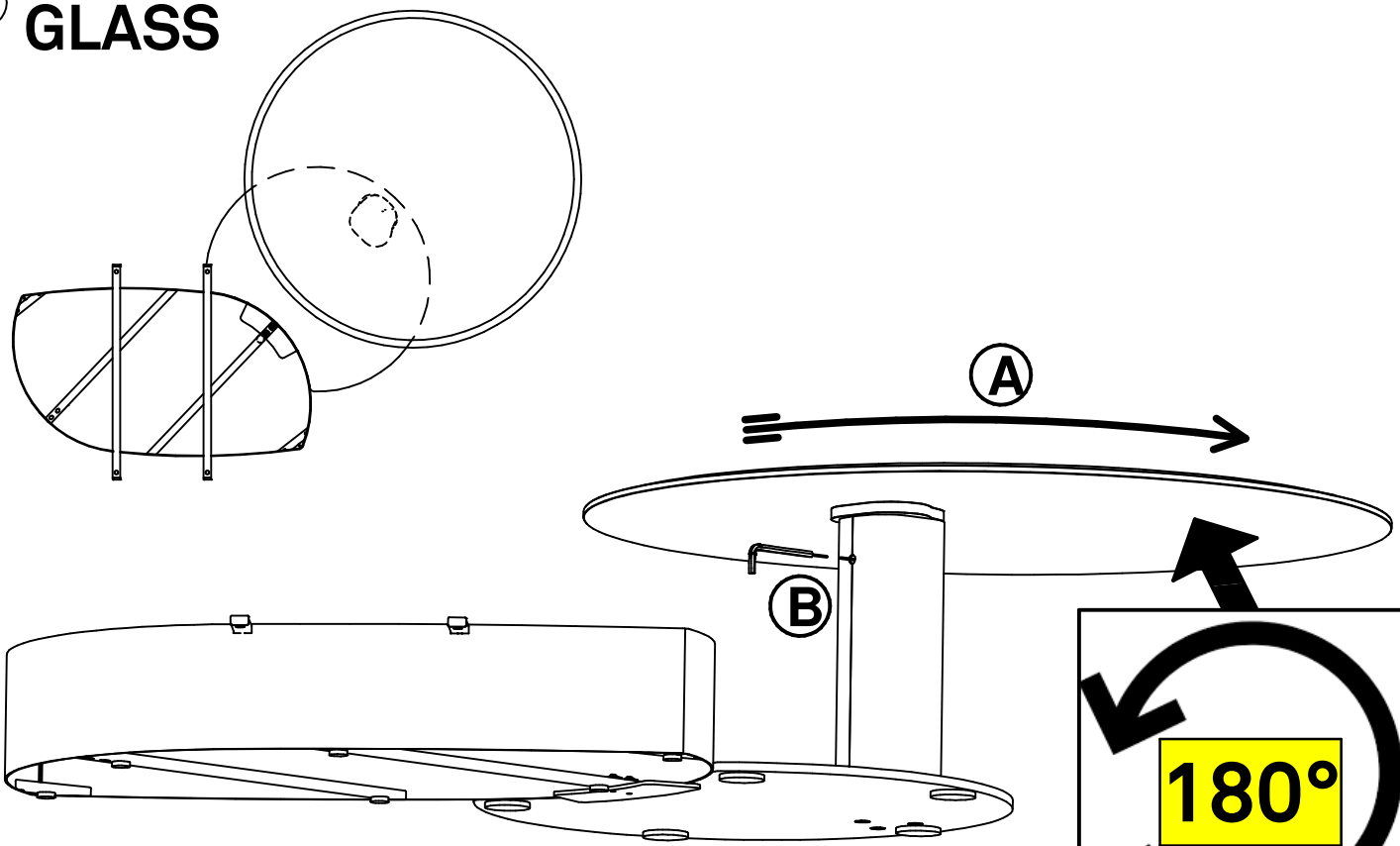

IMPORTANTE!
VERY IMPORTANT!
WICHTIG!
TRÈS IMPORTANT!
¡MUY IMPORTANTE!
BAKHHO
警告

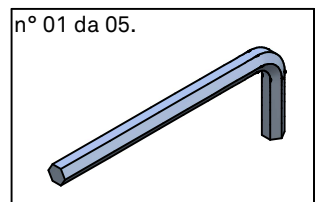
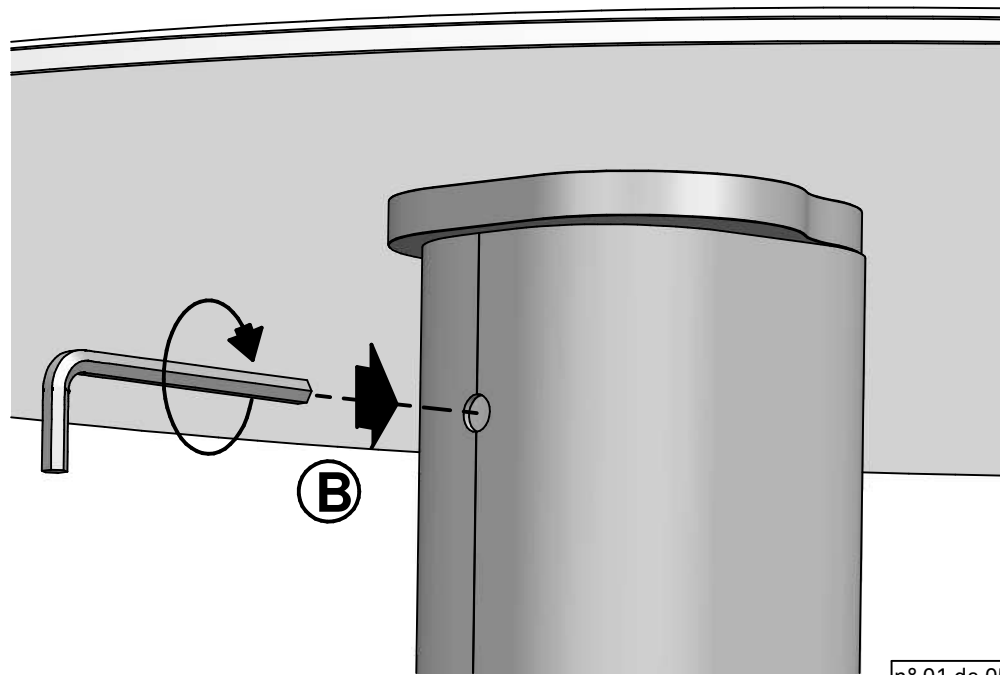

7

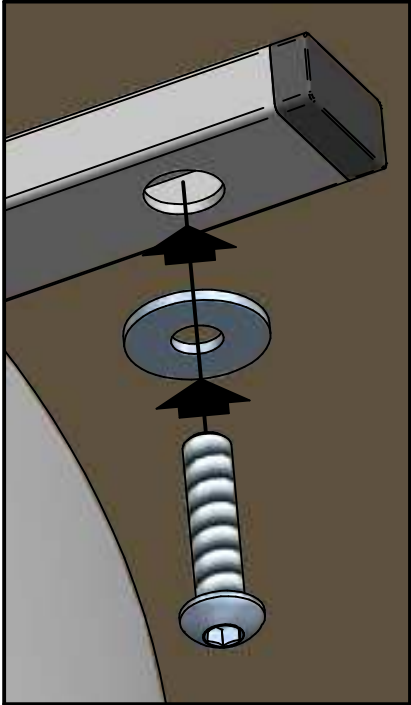
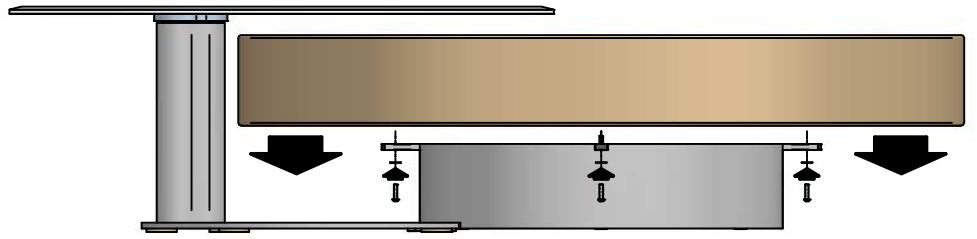

n° 04 TBCE M6x25 N.

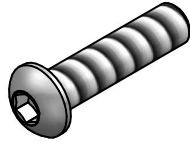

n° 04 ø6x18 N.

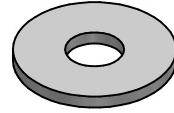

n° 01 da 04.

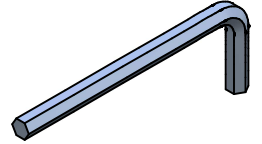

IT **USO**

Il prodotto è destinato per l'utilizzo all'interno delle abitazioni con l'uso per il quale è stato realizzato.

SMALTIMENTO

Una volta dismesso, il prodotto od i suoi componenti non vanno dispersi nell'ambiente ma conferiti ai sistemi pubblici di smaltimento.

MANUTENZIONE

Non vanno assolutamente utilizzati strumenti metallici appuntiti o panni abrasivi per eliminare eventuali residui di sporco presenti sulla superficie del prodotto, in quanto possono danneggiare la superficie stessa. Non vanno assolutamente utilizzati detergenti che contengano cloro o a base di acido cloridrico, acido muriatico o prodotti anticalcare in quanto andrebbero ad alterare la brillantezza del prodotto.

BRUSHED BRONZE/BRUSHED GREY/BRUSHED BRASS

Le finiture Brushed Bronze, Brushed Grey e Brushed Brass sono il risultato di una lavorazione eseguita da un operatore che manualmente spazzola la superficie dopo una prima fase di verniciatura al fine di creare un effetto spazzolato irregolare. È pertanto necessario specificare che l'eventuale presenza di macchie e variazioni cromatiche non sono da considerarsi difetto, ma caratteristica intrinseca del prodotto in quanto la volontà di

CATTELAN ITALIA è quella di mantenere e sottolineare l'aspetto del fatto a mano. Non potremo pertanto accettare nessun tipo di reclamo legato a tali peculiarità.

EN **USE**

The product is intended for an indoor use and may only be used for its intended purpose.

DISPOSAL

If your furniture is unusable or unrepairable, neither the product nor its components are to be dispersed in the environment, but rather consigned to public disposal systems.

MAINTENANCE

It is recommended not to use metal sharp tools or abrasive clothes to eliminate dirt from the surface, because they could damage the same. Do not absolutely use detergents containing chlorine, muriatic acid, hydrochloric acid or descale detergents which can damage the surface brilliance.

BRUSHED BRONZE/BRUSHED GREY/BRUSHED BRASS

Brushed Bronze, Brushed Grey and Brushed Brass finishes are the result of a manual processing by a worker/an operator who manually brushes the surface after the first painting phase, in order to create an irregular brushed effect. The Brushed Bronze finish is the result of a manual processing. The presence of stains and colour variations should not be considered a defect, but value and uniqueness of the item (a real item feature) since the purpose of CATTELAN ITALIA is to evaluate this hand-made work. Therefore, we will not be able to accept any kind of complaint related to these peculiarities.

DE **NUTZUNG**

Das Produkt ist nur für den Innenbereich gedacht. Der Tisch wurde hergestellt, nur als Esstisch genutzt zu werden.

ENTSORGUNG

Nach der Aussonderung ist das Produkt und seine Bestandteile nicht selbständig im Freien zu entsorgen, sondern der städtischen Müllabfuhr zu übergeben.

WARTUNG

Niemals scharfe Werkzeuge aus Metall, spitzen Instrumente oder Schleifmittel für die Reinigung der Oberfläche verwenden. Diese Produkte können die Oberfläche beschädigen. Niemals Chemikalien mit chlorhaltigen Salzsäure, Salzsäure oder Kalk-Produkte für die Reinigung verwenden. Diese Produkte können der Glanz beschädigen.

BRUSHED BRONZE/BRUSHED GREY/BRUSHED BRASS

Die Ausführungen Brushed Bronze, Brushed Grey und Brushed Brass sind das Ergebnis eines Bearbeitungsprozesses durch einen Bediener geführt. Nach einem ersten Beschichtungsphase, wird die Oberfläche manuell gebürstet, um einen unregelmäßigen gebürsteten Effekt zu erzeugen. Ist daher notwendig, zu spezifizieren, dass das mögliche Vorhandensein von Flecken und chromatischen Variationen nicht als Defekt des Materials anzusehen wird, sondern intrinsische Eigenschaft des Produkts. Der Wunsch von CATTELAN ITALIA ist das Aussehen der handgearbeiteten Ausführung. Auf diesem Grund kann für die Einzigartigkeit des Aussehens keine Beanstandung akzeptiert werden.

FR **UTILISATION**

Le produit est destiné pour une utilisation à l'intérieur des habitations.

ECOULEMENT

Une fois disloqué, le produit ou ses composants ne doivent pas être dispersés dans la nature mais confiés aux décharges publiques.

MANUTENTION

Il ne faut pas absolument utiliser des outils pointus ou des chiffons abrasifs pour éliminer des possibles restes sur la surface du produit, parce qu'ils peuvent endommager la surface même. Ne pas utiliser des détergents contenant du chlore, acide chlorhydrique, acide muriatique ou produits anticalcare qui peuvent altérer le brillant du produit.

BRUSHED BRONZE/BRUSHED GREY/BRUSHED BRASS

Les finitions Brushed Bronze, Brushed Grey et Brushed Brass sont le résultat d'une opération effectuée par un opérateur qui brosse manuellement la surface après une première étape de peinture afin de créer un effet brossé irrégulier. Il est donc nécessaire de préciser que la présence plus ou moins évidente de taches et variations chromatiques ne peut pas être considérée comme défauts mais valeurs et unicités du produit (caractéristiques intrinsèques du produit), la volonté de CATTELAN ITALIA est celle de maintenir et souligner l'aspect du traitement manuel. Par conséquent, aucune réclamation ne sera acceptée en référence à ces particularités.

El producto está destinado para su uso dentro del hogar, a los fines por los cuales fue creado.

ELIMINACIÓN DE DESECHOS

Una vez desechado, el producto o sus componentes no se tienen que abandonar en el entorno sino entregar al sistema público de recogida de basuras.

MANTENIMIENTO

No utilizar en cualquier forma instrumentos de metal afilados o telas abrasivas para eliminar cualquier resto de suciedad en la superficie del producto, ya que pueden dañar la superficie misma. No utilizar en cualquier forma limpiadores a base de cloro o que contienen ácido clorhídrico, ácido muriático o productos anticalcáreos ya que pueden alterar el brillo del producto.

BRUSHED BRONZE/BRUSHED GREY/BRUSHED BRASS

Los acabados Brushed Bronze, Brushed Grey y Brushed Brass identifican un tipo de fabricación manual donde el operador cepilla la superficie después de una primera fase de pintura con el fin de crear un efecto cepillado irregular. La posible presencia de manchas y variaciones de color no se considera defecto, al contrario representa una característica de un producto precioso y único. El propósito por CATTELAN ITALIA es lo de subrayar el valor de un producto hecho a mano. No se aceptarán entonces reclamaciones en referencia a esta peculiaridad.

ИСПОЛЬЗОВАНИЕ

Изделие предназначено для использования внутри помещения.

УТИЛИЗАЦИЯ

После утилизации, продукт и его компоненты не должны разлагаться в окружающей среде, а должны быть переданы в специализированные места утилизации.

УХОД

Не используйте острые металлические инструменты или абразивные губки для удаления грязи, так как они могут повредить поверхности. Ни в коем случае не используйте моющие средства, содержащие хлор, соляную кислоту или средства от известкового налета, поскольку они могут повлиять на блеск предмета.

BRUSHED BRONZE/BRUSHED GREY/BRUSHED BRASS

Отделки Brushed Bronze, Brushed Grey и Brushed Brass являются результатом работы, проводимой вручную, путем брашировки поверхности после первой фазы окрашивания для получения в итоге эффекта неровности. Необходимо заметить, что возможные пятна и следы хрома не могут считаться дефектом, а напротив, характеристикой, присущей этом товару, так как CATTELAN ITALIA хотела бы обозначить и подчеркнуть факт ручной работы. Претензии к подобным особенностям продукта не принимаются

使用:

此产品仅限于室内使用，也只能按其用途使用。

处理方法：

如果家具不能使用或是不能修复，不要把产品及其部件散步在外面，应将其交由公共处置系统。

保养:

不建议使用锋利的金属工具或磨料织物去除表面上的污垢，因为它们可能会损害产品。请勿使用含有氟林，盐酸，氢氟酸的洗涤剂或浓缩洗涤剂清理产品，因为它们会破坏产品表面的光泽。

BRUSHED BRONZE/BRUSHED GREY/BRUSHED BRASS

十字拉丝青铜色和灰色漆饰面，是由工人在第一个油漆阶段之后，通过手工刷过表面来创造不规则的拉丝效果。最终拉丝青铜的饰面是完全手工处理的结果。因为CATTELAN ITALIA的目标就是体现它的手工艺，所以饰面上所出现的斑点和颜色差异不应被当做是瑕疵，而是这款饰面的特色和价值，这些是一个真正的产品特色。因此，我们不接受任何关于这种饰面特色的投诉。

**cattelan
italia**

CATTELAN ITALIA SPA
Via Pilastri, 19
36010 Carré (VI), Italy
Ph. +39 0445 318711
info@cattelanitalia.com
www.cattelanitalia.com

