

ATTENZIONE: Il corretto funzionamento dell'articolo è garantito solo con l'uso appropriato delle seguenti istruzioni, pertanto è necessario conservarle.

WARNING: For the correct assembly of this item, keep to the instructions contained herein, which should be left in a safe place for future reference.











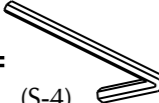

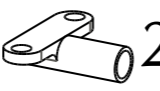

ATTENTION : le bon fonctionnement de cet article n'est garanti qu'en cas d'application stricte des instructions suivantes qui sont à conserver.

ACHTUNG: Die korrekte Funktionsweise des Artikels ist nur durch angemessene Befolgung nachstehender Anleitungen gewährleistet; bewahren Sie diese demnach sorgsam auf.

ATTENCION: El correcto funcionamiento del artículo esta garantizado solamente con el uso apropiado de las instrucciones adjuntas, por ello es necesario conservarlas.

ВНИМАНИЕ: Правильное функционирование данного артикула гарантировано только при использовании следующей инструкции, поэтому ее необходимо сохранять.

- (I) Istruzione di montaggio, uso e manutenzione da consegnare al consumatore finale. Per la pulizia utilizzare un panno di cotone umido d'acqua.
- (GB) Assembly, use and maintenance instructions for the end user. Use a wet cotton cloth for cleaning. Please use only water.
- (D) Montage-, Gebrauchs- und wartungsanleitung; an den Endverbraucher auszuhändigen. Ein nasses Tuch in Baumwolle benutzen für die Reinigung. Nur Wasser brauchen.
- (F) Instruction de montage, d'utilisation et d'entretien, à remettre au consommateur final. Pour le nettoyage utiliser un drap de coton humide. Utiliser seulement de l'eau. Les instructions de montage, utilisation et entretien doivent être remises au consommateur final. Pour la limpieza se debe utilizar un paño de algodón húmedo. Utilizar solo agua.
- (E) Инструкция монтажа, использования и технического обслуживания для передачи конечному потребителю. Для ухода использовать влажную хлопчатобумажную ткань

A =  8 (4,8x13)	B =  1 (S-4)	C =  25 (6MAx20)	D =  2	E =  4 (6MAx12)	F =  4 (D-18x2 F.6,5)	G =  4 (6MAx16)	H =  6 (M14x1,5 H8mm)	I =  6 (M14x1,5 H13mm)	L =  6 (6MAx50)	
M =  6 (ES-17X25 6MA)	N =  6 (M6X12-M4X9)	O =  6 (6MAx35)	P =  1 (125X40 SP.20/10)	Q =  1 (S-3)						

(I) SE NON SPECIFICATO, IMPRONTARE SOLO LE VITI SENZA SERRARLE
 (GB) UNLESS STATED OTHERWISE, FIT THE SCREWS LOOSELY
 (D) wenn nicht angegeben, bitte die Schrauben fest machen ohne diese sperren
 (F) SI NON SPECIFIE, APPUYER SEULEMENT LES VIS SANS LES SERRER
 (E) SALVO INDICACIÓN CONTRARIA, POSICIONAR LOS TORNILLOS SIN AJUSTAR POR COMPLETO
 (RU) ЕСЛИ НЕ УКАЗАНО, ТОЛЬКО ВСТАВИТЬ ВИНТЫ, НЕ ЗАВИНЧИВАЯ ИХ

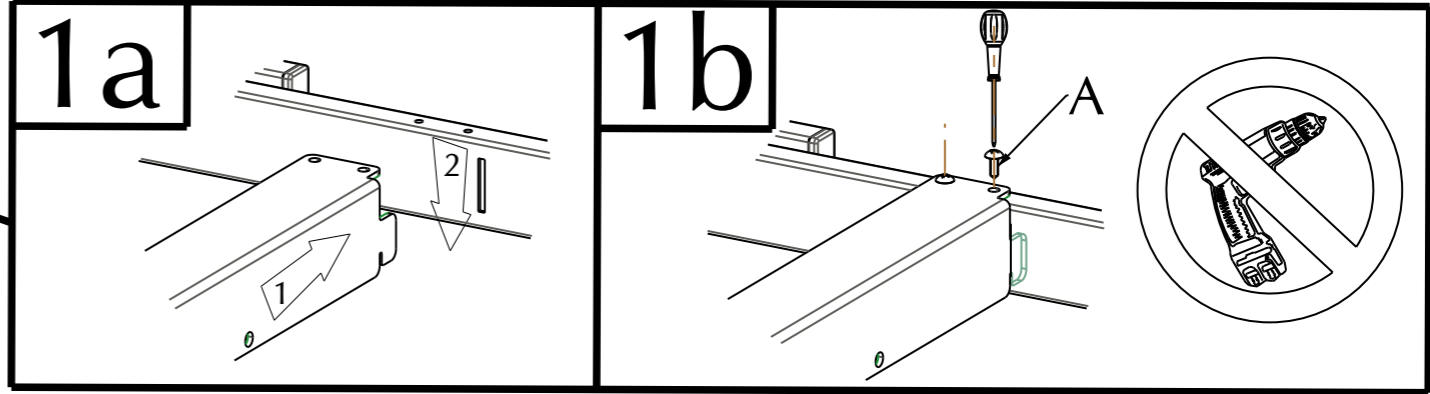
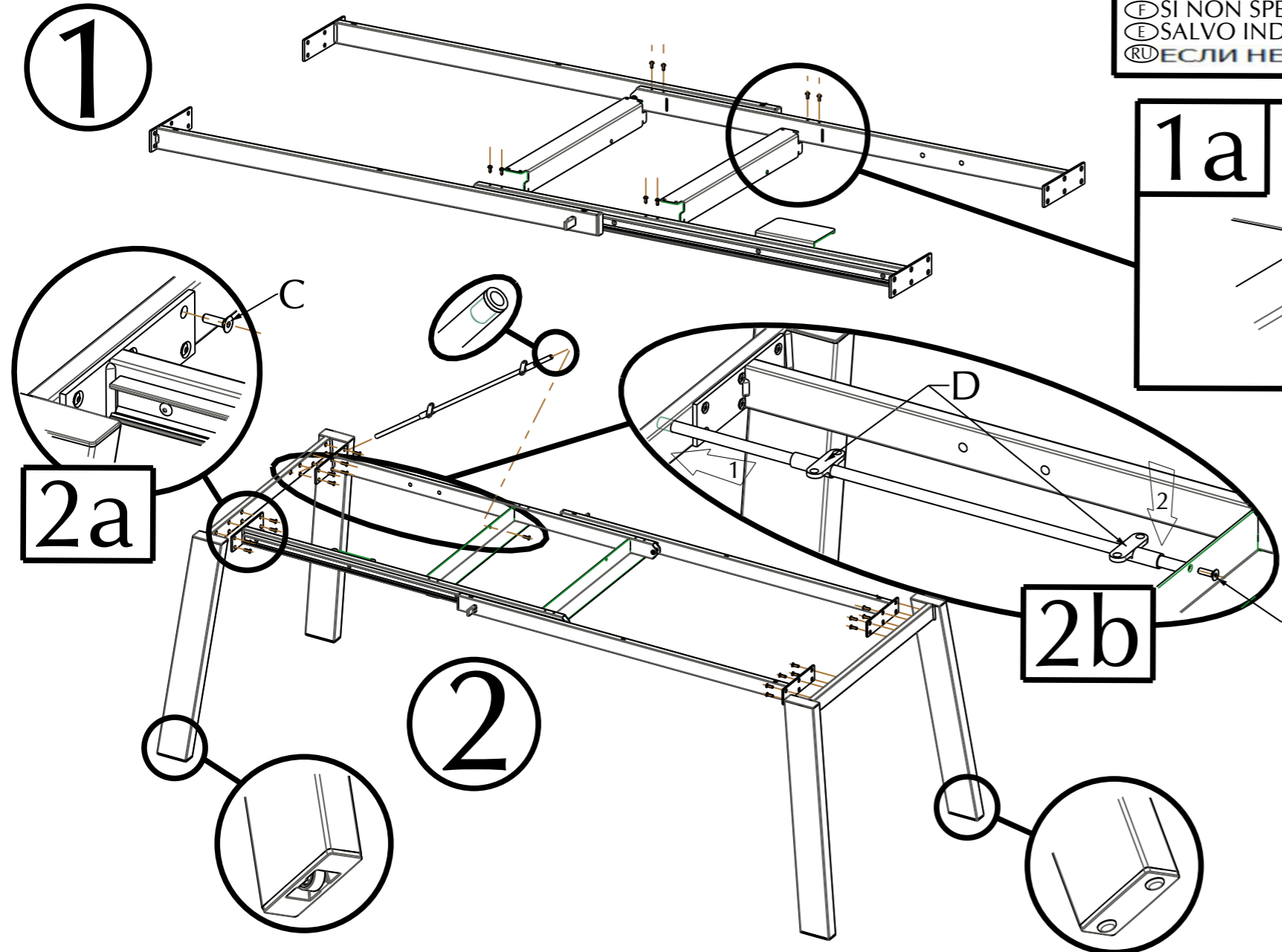

- (I) CHIUDERE IL TELAIO
- (GB) CLOSE THE FRAME
- (D) Gestell schließen
- (F) FERMER LE CHÂSSIS
- (E) CERRAR LA ESTRUCTURA
- (RU) ЗАКРЫТЬ РАМУ

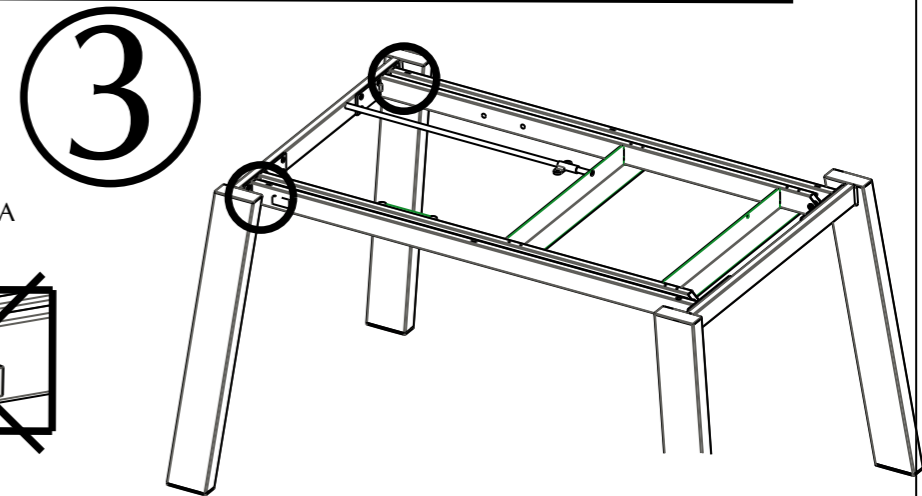
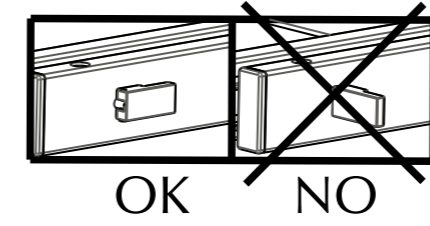

(I) SERRARE TUTTE LE VITI
 (GB) TIGHTEN ALL THE SCREWS
 (D) Alle Schrauben sichern
 (F) SERRER TOUTES LES VIS
 (E) AJUSTAR TODOS LOS TORNILLOS
 (RU) ЗАКРУТИТЬ ВСЕ ВИНТЫ

4

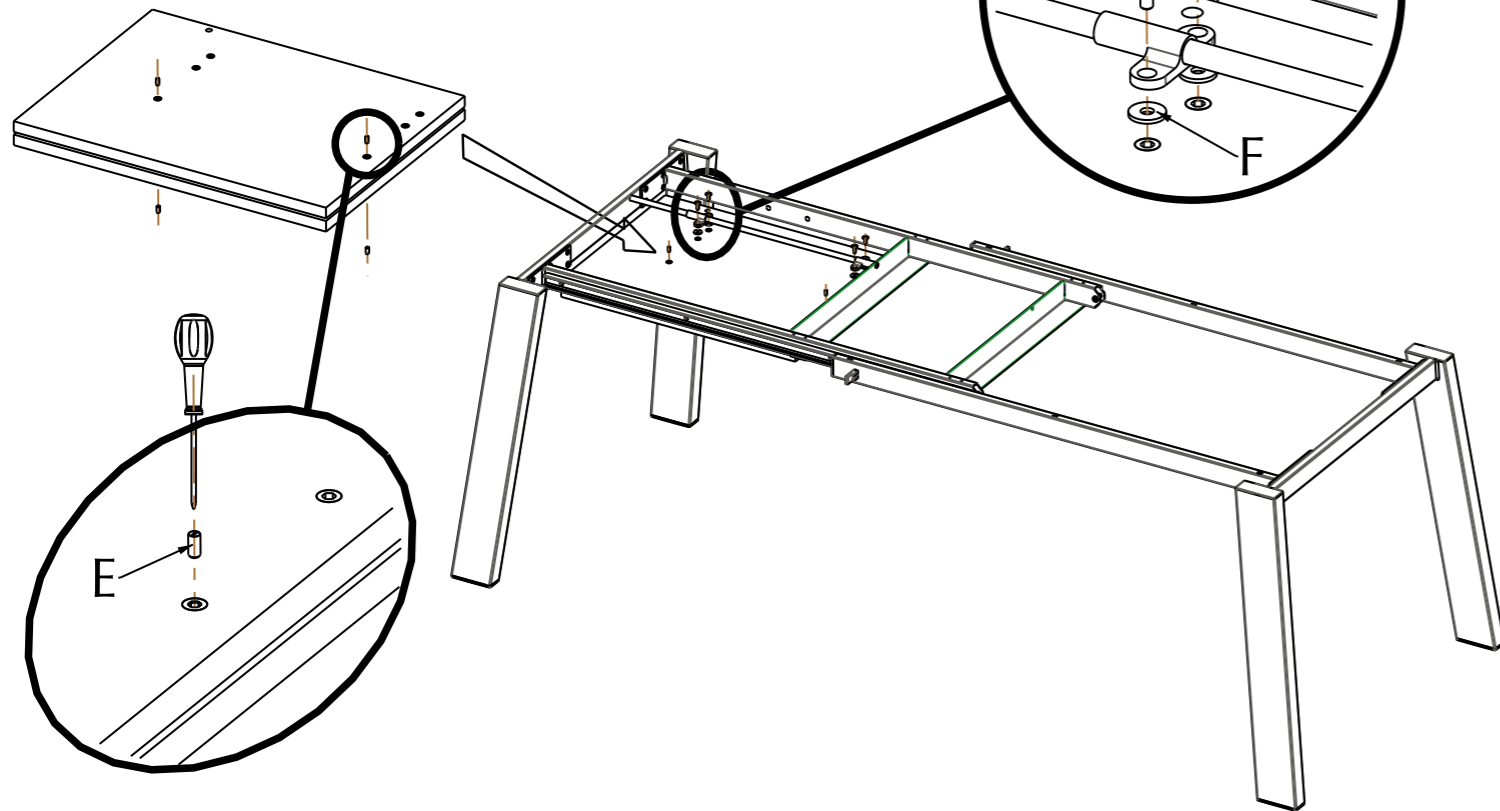

5A

- Ⓛ PIANO IN CRISTALLO
- ⒸB GLASS TOP
- Ⓛ PLATTE AUS GLAS
- ⒸF PLATEAU EN CRISTAL
- Ⓛ SOBRE EN CRISTAL
- ⒸRU СТОЛЕШНИЦА ИЗ СТЕКЛА

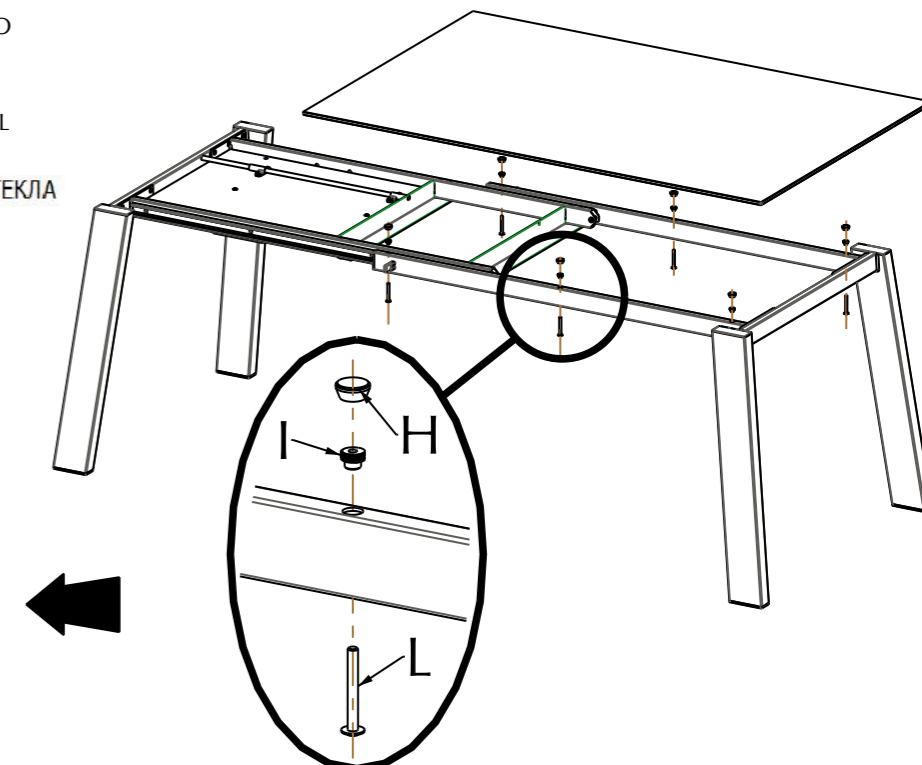
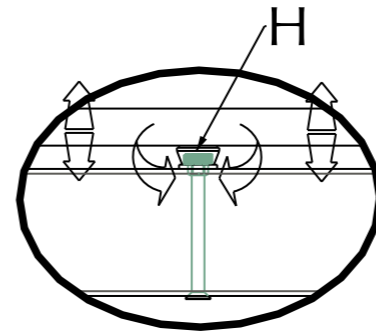

- Ⓛ Ruotare il particolare (H) per regolare planarità e altezza del top
- ⒸB Turn part (H) to adjust the heightband flatness top
- Ⓛ Drehen Sie Teil (H), um die Höhe und Ebenheit oben anpassen
- ⒸF Tourner le particulier (H) pour ajuster la hauteur et de planéité des plateau
- Ⓛ Girar el particular (H) para ajustar la altura y la parte superior planitud de tapa
- ⒸRU Вращать деталь (H) для регулирования ровности и высоты столешницы

5B

- Ⓛ PIANO IN LEGNO
- ⒸB WOODEN TOP
- Ⓛ HOLZPLATTE
- ⒸF PLATEAU BOIS
- Ⓛ SOBRE EN MADERA
- ⒸRU СТОЛЕШНИЦА ИЗ ДЕРЕВА

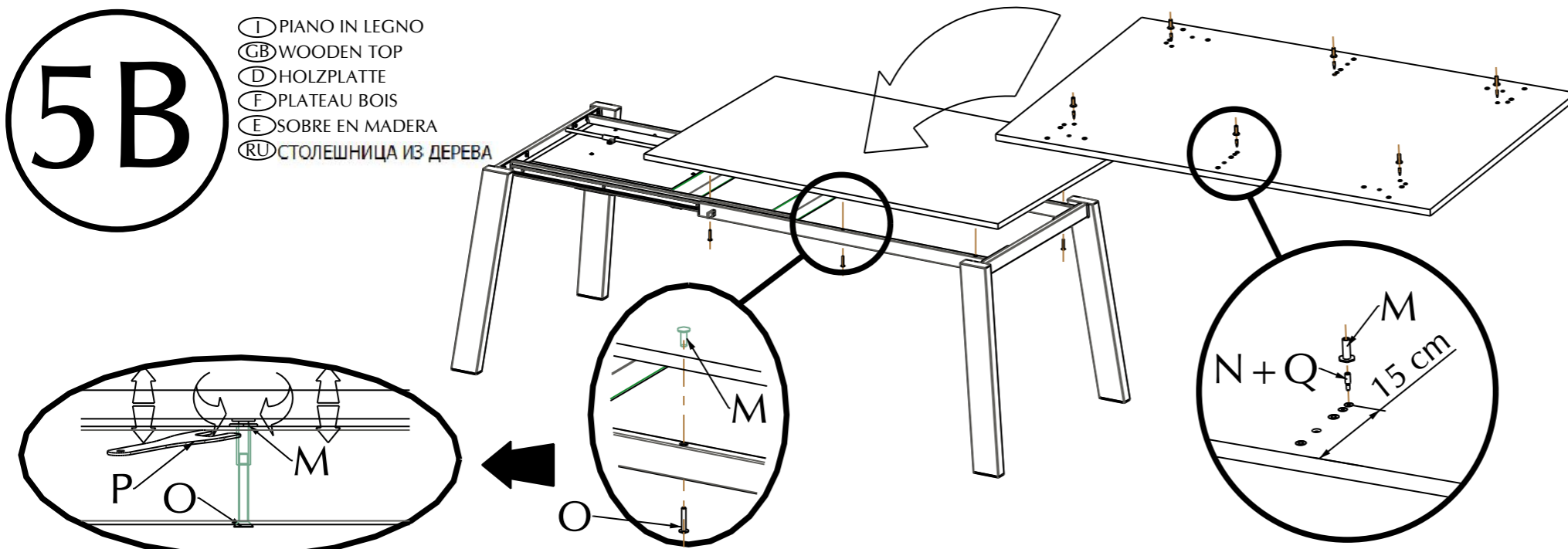

- Ⓛ A tavolo aperto posizionare il piano sul telaio come in figura. Regolarlo in altezza avvitando e svitando le viti (M-O)
- ⒸB When table is open position the top as shown in the figure. Adjust it in height by screwing and unscrewing the screws (M-O)
- Ⓛ Wenn Tisch ausgezogen ist die Platte auf den Rahmen positionieren wie auf dem Bild.
- ⒸF Platte in der Höhe durch an - und abschrauben einstellen (M-O)
- Ⓛ A table ouverte positionner le plateau comme dans la figure. Régler en hauteur en vissant et dévissant les vis (M-O)
- Ⓛ Con la mesa abierta colocar el sobre sobre la estructura como en la figura. Regularlo en altura enroscando y desenroscando los tornillos (M-O)
- ⒸRU На раскрытом столе устанавливать столешницу на раму, как показано на рисунке. Регулировать по высоте, закручивая и развинчивая винты (M-O)

6

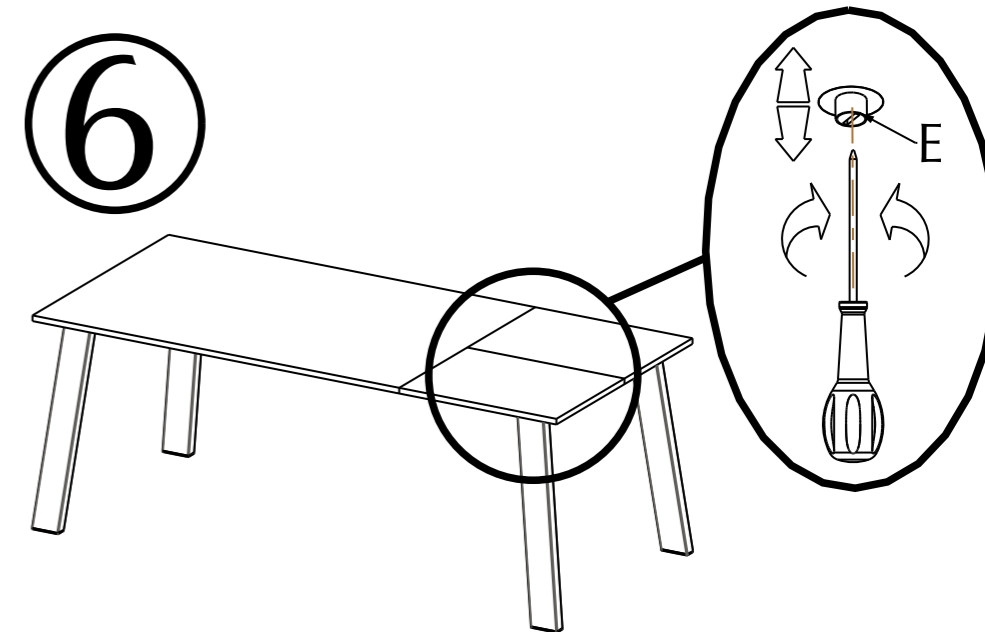

- Ⓛ Ruotare il particolare (E) per regolare planarità e altezza delle prolungh
- ⒸB Rotate the particular (E) to adjust height and flatness of the extensions
- Ⓛ Drehen des insbesondere (E) und Höhe und Ebenheit der Verlängerungen einstellen
- ⒸF Tourner le particulier (E) pour ajuster la hauteur et de planéité des extensions
- Ⓛ Girar el particular, (E) para ajustar la altura y la planeidad de las extensiones
- ⒸRU Вращать деталь (E) для регулирования ровности и высоты удлинителей