

# ISTRUZIONI / INSTRUCTIONS

**nicoline**

SCHEDA MONTAGGIO LETTO  
LEGS ASSEMBLY INSTRUCTIONS BED

LM13

LETTO DAFNE

## ELEMENTI PER GIROLETTO / XXX BED FRAME ELEMENTS

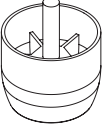
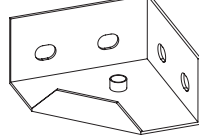
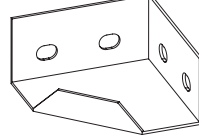
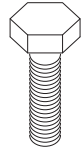
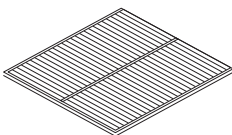
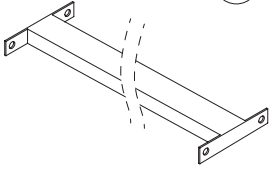
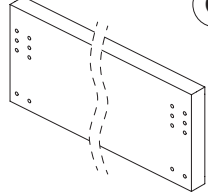
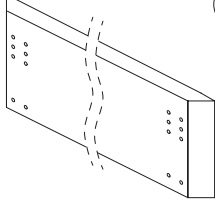
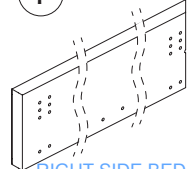
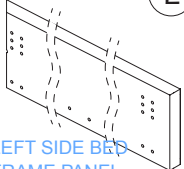
<p><b>(A)</b></p>  <p>PIEDE IN PLASTICA (4PZ) PLASTIC LEGS (4pcs)</p>	<p><b>(B)</b></p>  <p>STAFFA ANGOLARE INFERIORE (4PZ) LOWER ANGLE BRACKET (4pcs)</p>	<p><b>(C)</b></p>  <p>STAFFA ANGOLARE SUPERIORE (4PZ) UPPER ANGLE BRACKET (4pcs)</p>	<p><b>(D)</b></p>  <p>VITI (52PZ) SCREWS (52PZ) (53pcs)</p>	<p><b>(E)</b></p>  <p>RETE LETTO (1PZ) BED BASE (1pc)</p>
<p><b>(F)</b></p>  <p>BARRA CENTRALE (1PZ) CENTRAL BOARD (1pc)</p>	<p><b>(G)</b></p>  <p>PANN. GIROLETTO POSTERIORE (1PZ) REAR BED FRAME PANEL (1pc)</p>	<p><b>(H)</b></p>  <p>PANN. GIROLETTO ANTERIORE (1PZ) FRONT BED FRAME PANEL (1pc)</p>	<p><b>(I)</b></p>  <p>RIGHT SIDE BED FRAME PANEL (1pc)</p> <p>PANN. GIROLETTO LATERALE DX (1PZ)</p>	<p><b>(L)</b></p>  <p>LEFT SIDE BED FRAME PANEL (1pc)</p> <p>PANN. GIROLETTO LATERALE SX (1PZ)</p>

## ELEMENTI PER TESTIERA / XXX HEADBOARD ELEMENTS

### PANNELLO / PANEL

7907: 16PZ  
7507: 16PZ  
7807: 14PZ  
7657: 14PZ

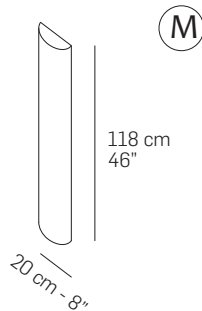

### STAFFE\* / BRACKETS\*

7907: X=160cm (4pz)  
7507: X=160cm (4pz)  
7807: X=140cm (4pz)  
7657: X=140cm (4pz)

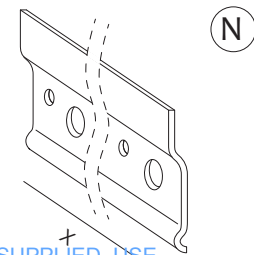

\*CREWS FOR WALL MOUNTING NOT SUPPLIED. USE SCREWS AND DOWELS SUITABLE FOR THE FIXING WALL.

\* VITI PER FISSAGGIO A MURO NON FORNITE. UTILIZZARE VITI E TASSELLI ADATTI ALLA PARETE DI FISSAGGIO.

## FASI DI MONTAGGIO GIROLETTO / XXX BED FRAME ASSEMBLY STEPS

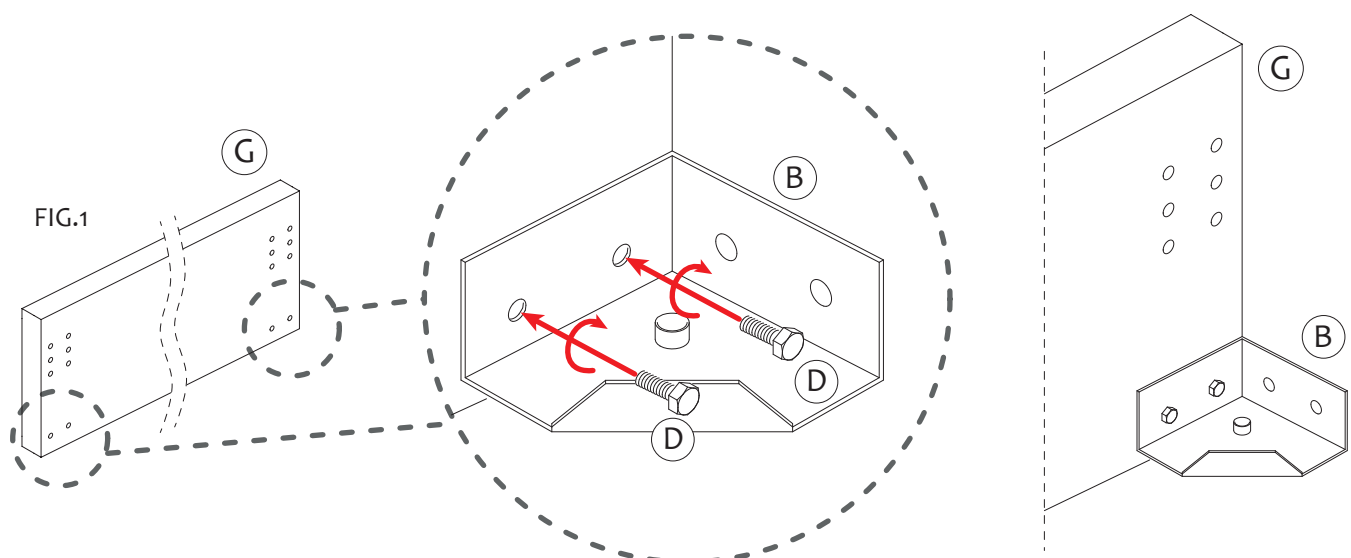

POSIZIONARE N.2 STAFFE ANGOLARI INFERIORI (B) IN PROSSIMITÀ DEI FORI INFERIORI DEL PANNELLO POSTERIORE (G). (VEDI FIG.1) FISSARE OGNUNA CON N.2 VITI (D).

POSITION N.2 LOWER ANGLE BRACKETS (B) NEAR THE LOWER HOLES OF THE REAR PANEL (G). (SEE FIG.1) FIX EACH WITH NO.2 SCREWS (D).

# ISTRUZIONI / INSTRUCTIONS

**nicoline**

SCHEDA MONTAGGIO LETTO  
LEGS ASSEMBLY INSTRUCTIONS BED

LM13

LETTO MOZART

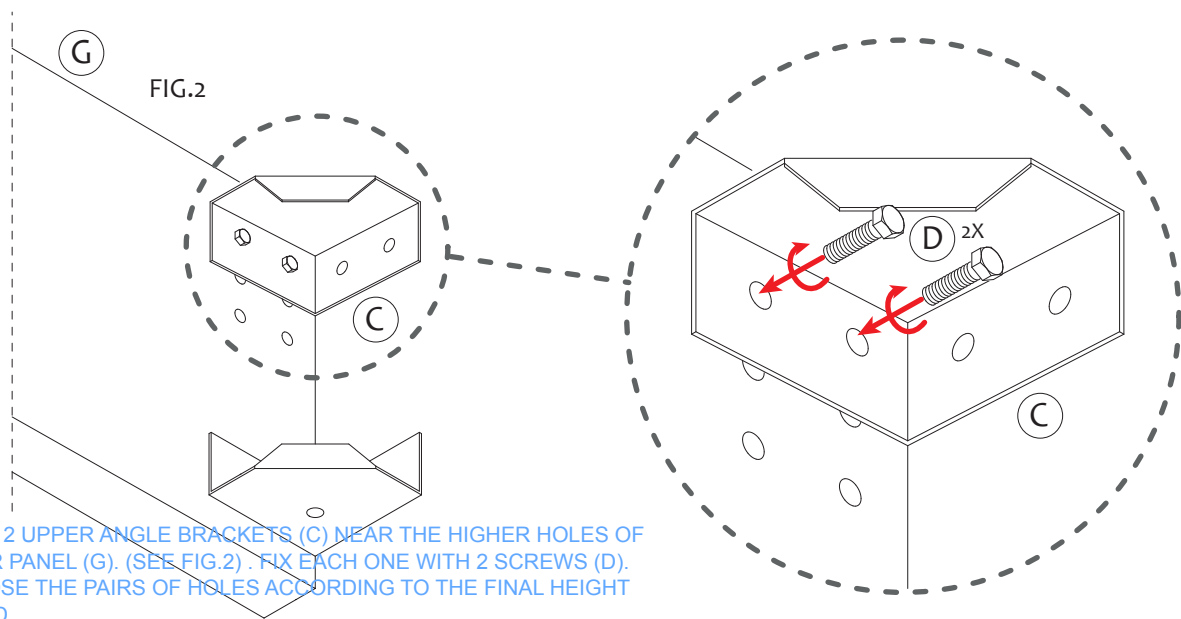

POSITION 2 UPPER ANGLE BRACKETS (C) NEAR THE HIGHER HOLES OF THE REAR PANEL (G). (SEE FIG.2) . FIX EACH ONE WITH 2 SCREWS (D). NB. CHOOSE THE PAIRS OF HOLES ACCORDING TO THE FINAL HEIGHT REQUIRED.

POSIZIONARE N.2 STAFFE ANGOLARI SUPERIORI (C) IN PROSSIMITÀ DEI FORI SUPERIORI DEL PANNELLO POSTERIORE (G). (VEDI FIG.2) . FISSARE OGNUNA CON N.2 VITI (D). NB. SCEGLIERE LE COPPIE DI FORI IN FUNZIONE DELL'ALTEZZA FINALE DESIDERATA.

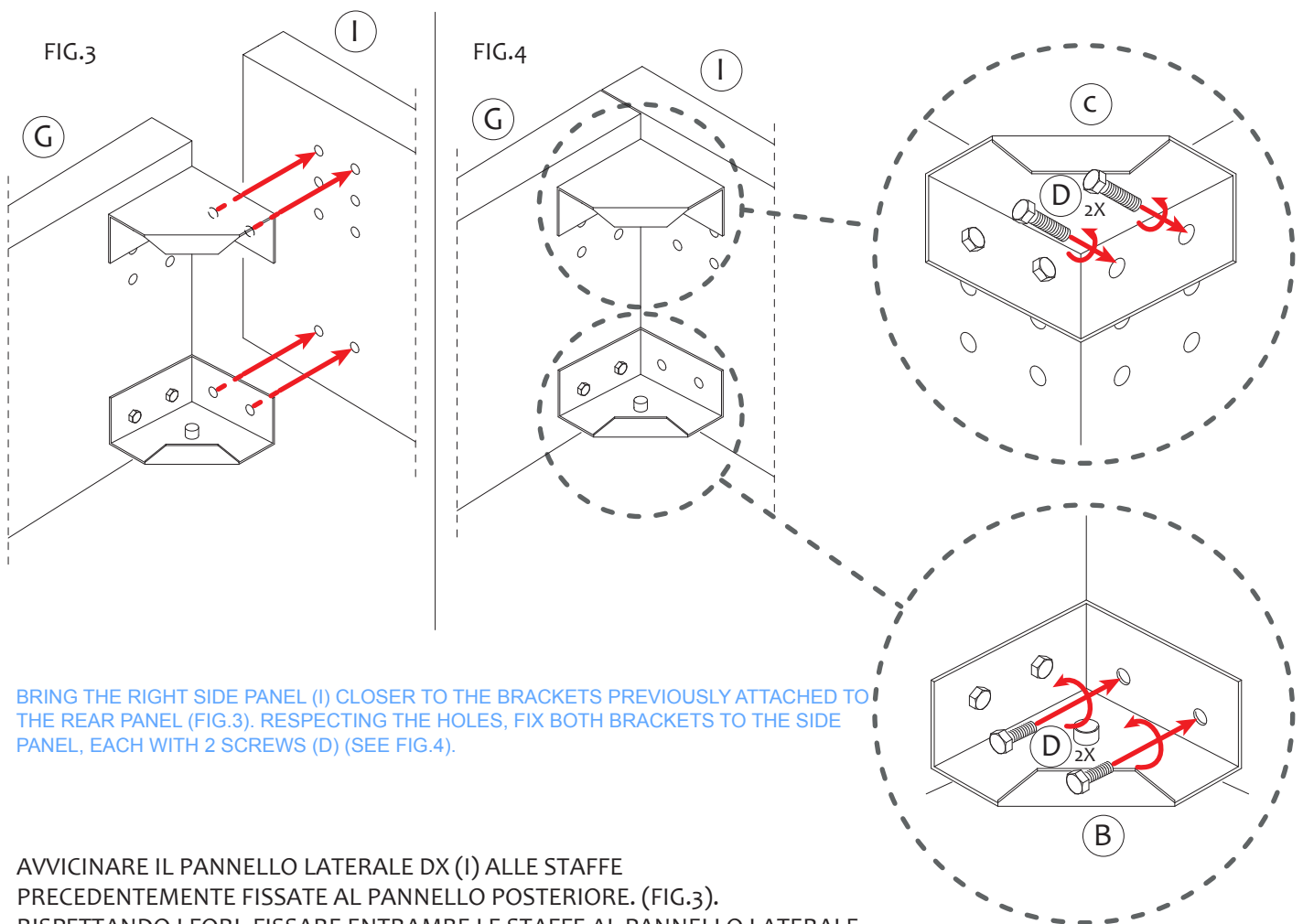

BRING THE RIGHT SIDE PANEL (I) CLOSER TO THE BRACKETS PREVIOUSLY ATTACHED TO THE REAR PANEL (FIG.3). RESPECTING THE HOLES, FIX BOTH BRACKETS TO THE SIDE PANEL, EACH WITH 2 SCREWS (D) (SEE FIG.4).

AVVICINARE IL PANNELLO LATERALE DX (I) ALLE STAFFE PRECEDENTEMENTE FISSATE AL PANNELLO POSTERIORE. (FIG.3). RISPETTANDO I FORI, FISSARE ENTRAMBE LE STAFFE AL PANNELLO LATERALE, OGNUNA CON N.2 VITI (D) (VEDI FIG.4).

# ISTRUZIONI / INSTRUCTIONS

**nicoline**

SCHEDA MONTAGGIO LETTO  
LEGS ASSEMBLY INSTRUCTIONS BED

LM13

LETTO MOZART

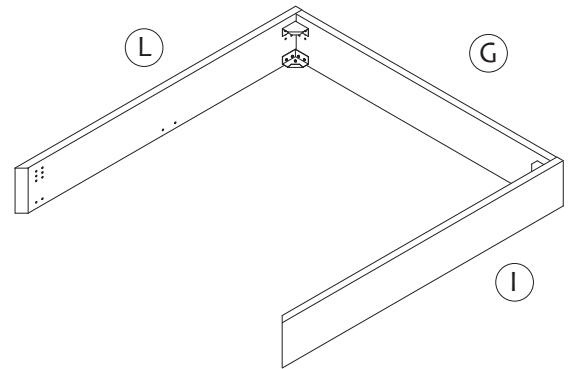
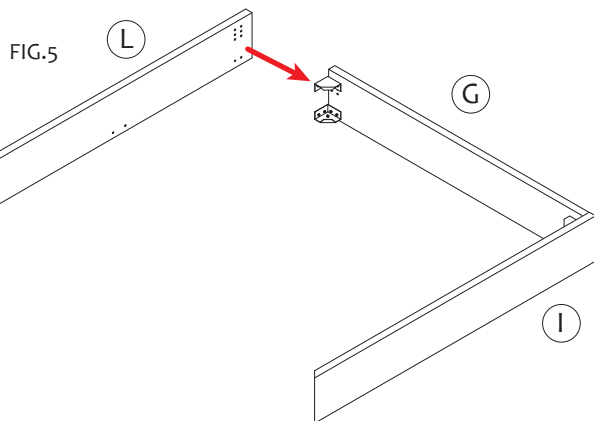

BRING THE LEFT SIDE PANEL (L) CLOSER TO THE STRUCTURE AND REPEAT THE OPERATION DESCRIBED ABOVE (SEE FIG. 5)

AVVICINARE IL PANNELLO LATERALE SX (L) ALLA STRUTTURA E RIPETERE L'OPERAZIONE PRECEDENTEMENTE DESCRITTA (VEDI FIG.5)

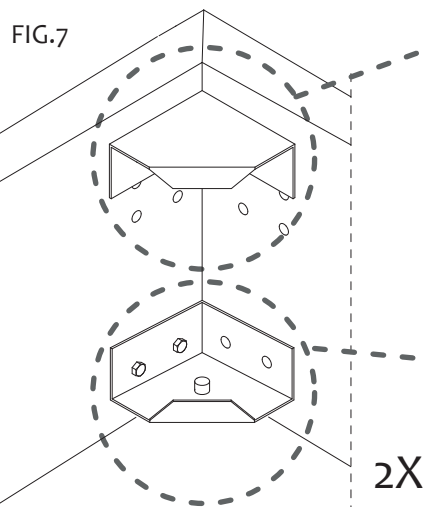
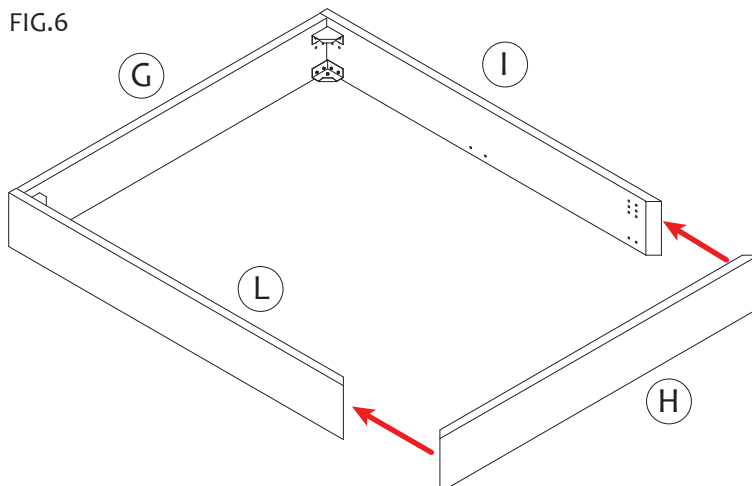

BRING THE FRONT PANEL (H) CLOSER TO THE REST OF THE STRUCTURE (FIG. 6). 3 RESPECTING THE HOLES, FIX THE FRONT PANEL TO THE STRUCTURE WITH THE REMAINING UPPER (2X) AND LOWER (2X) BRACKETS AS PREVIOUSLY ILLUSTRATED. (SEE FIG.7)

AVVICINARE IL PANNELLO ANTERIORE (H) AL RESTO DELLA STRUTTURA (FIG.6). RISPETTANDO I FORI, FISSARE IL PANNELLO ANTERIORE ALLA STRUTTURA CON LE RIMANENTI STAFFE SUPERIORI (2X) E INFERIORI (2X) COME PRECEDENTEMENTE ILLUSTRATO. (VEDI FIG.7)

# ISTRUZIONI / INSTRUCTIONS

**nicoline**

SCHEDA MONTAGGIO LETTO  
LEGS ASSEMBLY INSTRUCTIONS BED

LM13

LETTO MOZART

FIG.8

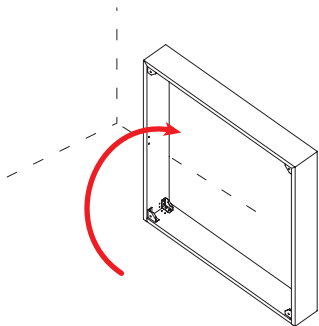
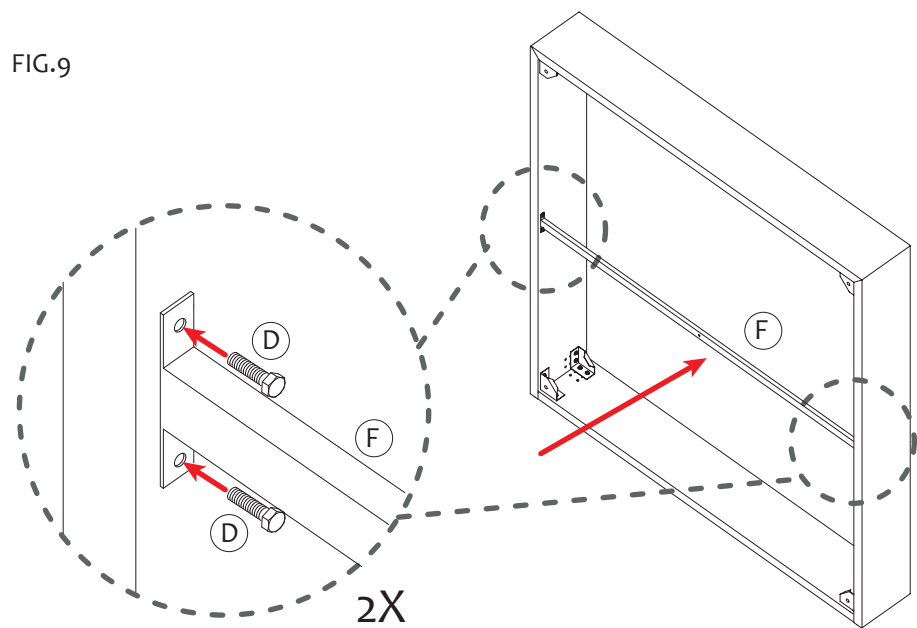

FIG.9



REVERSE THE BED FRAME BY PLACING THE REAR PANEL ON THE FLOOR. (FIG.8) BRING THE CENTRAL BAR (F) CLOSER TO THE FRAME NEAR THE HOLES IN THE SIDE PANELS AND SECURE IT WITH 2 SCREWS (D) PER SIDE (SEE FIG.9).

RIBALTARE LA STRUTTURA DEL GIROLETTO FACENDO POGGIARE IL PANNELLO POSTERIORE SUL PAVIMENTO. (FIG.8) AVVICINARE LA BARRA CENTRALE (F) ALLA STRUTTURA IN PROSSIMITÀ DEI FORI PRESENTI SUI PANNELLI LATERALI E FISSARLA CON CON N.2 VITI (D) PER LATO (VEDI FIG.9).

SCREW THE FOUR PLASTIC LEGS (A) INTO THEIR RESPECTIVE SLOTS IN THE LOWER BRACKETS (SEE FIG. 10).

REVERSE THE BED UP BY PLACING THE LEGS ON THE FLOOR. IF THE HEADBOARD PANELS ARE NOT TO BE INSTALLED, COVER THE FRAME WITH THE FABRIC (IN THE CASE OF THE REMOVABLE COVER VERSION) AND PLACE THE BED BASE INSIDE THE BED FRAME (SEE FIG.11).

OTHERWISE FOLLOW THE HEADBOARD ASSEMBLY INSTRUCTIONS.

FIG.10

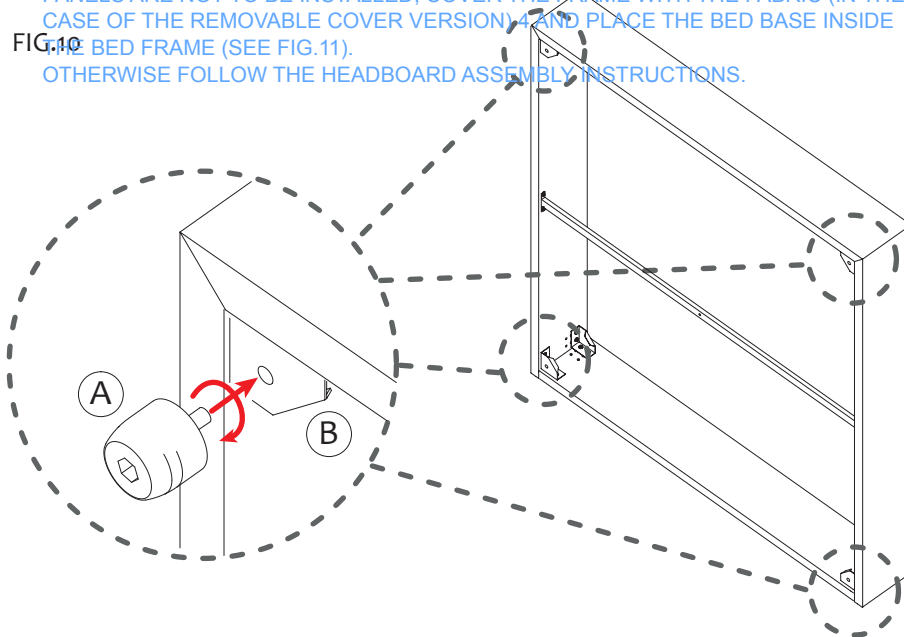
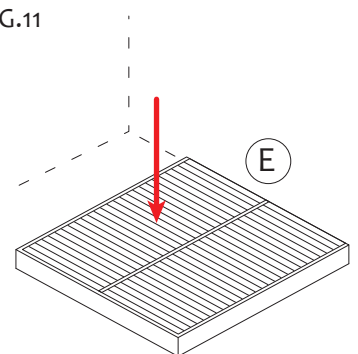

FIG.11



AVVITARE I QUATTRO PIEDI IN PLASTICA (A) NELLE RISPETTIVE SEDI DELLE STAFFE INFERIORI (VEDI FIG.10). RIBALTARE IL LETTO FACENDO POGGIARE I PIEDI SUL PAVIMENTO. SE NON SI DEVONO INSTALLARE I PANNELLI DELLA TESTIERA, RIVESTIRE LA STRUTTURA CON IL TESSUTO (NEL CASO DELLA VERSIONE SFODERABILE) E ALLOGGIARE LA RETE LETTO ALL'INTERNO DEL GIROLETTO (VEDI FIG.11). IN CASO CONTRARIO SEGUIRE LE ISTRUZIONI DEL MONTAGGIO TESTIERA.

# ISTRUZIONI / INSTRUCTIONS

**nicoline**

SCHEDA MONTAGGIO LETTO  
LEGS ASSEMBLY INSTRUCTIONS BED

LM13

LETTO MOZART

## FASI DI MONTAGGIO TESTIERA / **XXX** HEADBOARD ASSEMBLY STEPS

FIG.12

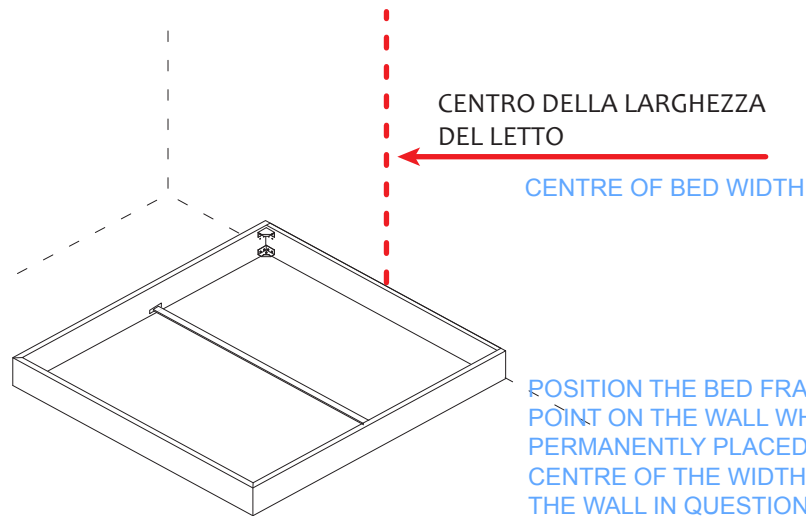

POSIZIONARE LA STRUTTURA DEL GIROLETTO NEL PUNTO ESATTO DELLA PARETE DOVE VERRÀ DEFINITIVAMENTE COLLOCATA E SEGNARE SULLA PARETE IN QUESTIONE IL CENTRO DELLA LARGHEZZA DELLA STRUTTURA. (FIG.8)

FIG.13

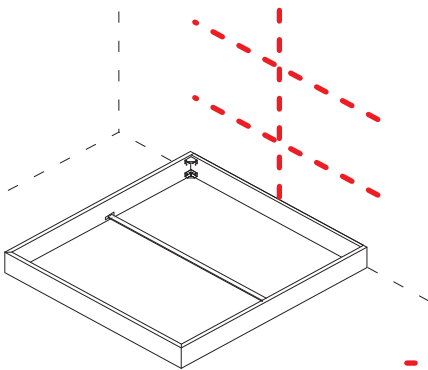
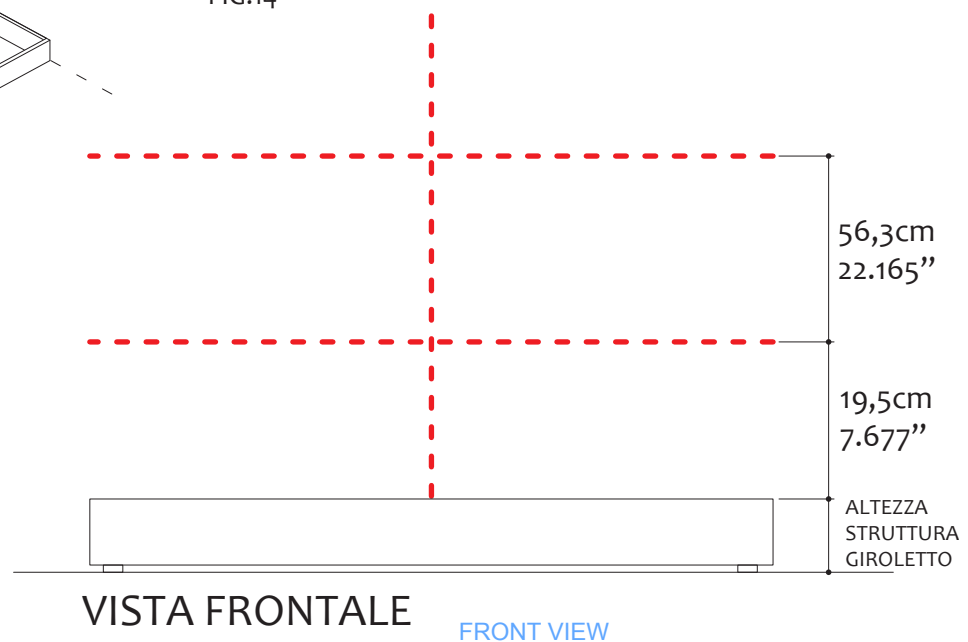

FIG.14



MARK TWO LINES PARALLEL TO THE FLOOR IN ACCORDANCE WITH THE DIMENSIONS IN THE FIGURE ABOVE (FIG.13-14).

SEGNARE DUE LINEE PARALLELE AL PAVIMENTO RISPETTANDO LE QUOTE DELLA FIGURA IN ALTO (FIG.13-14).

# ISTRUZIONI / INSTRUCTIONS

**nicoline**

SCHEDA MONTAGGIO LETTO  
LEGS ASSEMBLY INSTRUCTIONS BED

LM13

LETTO MOZART

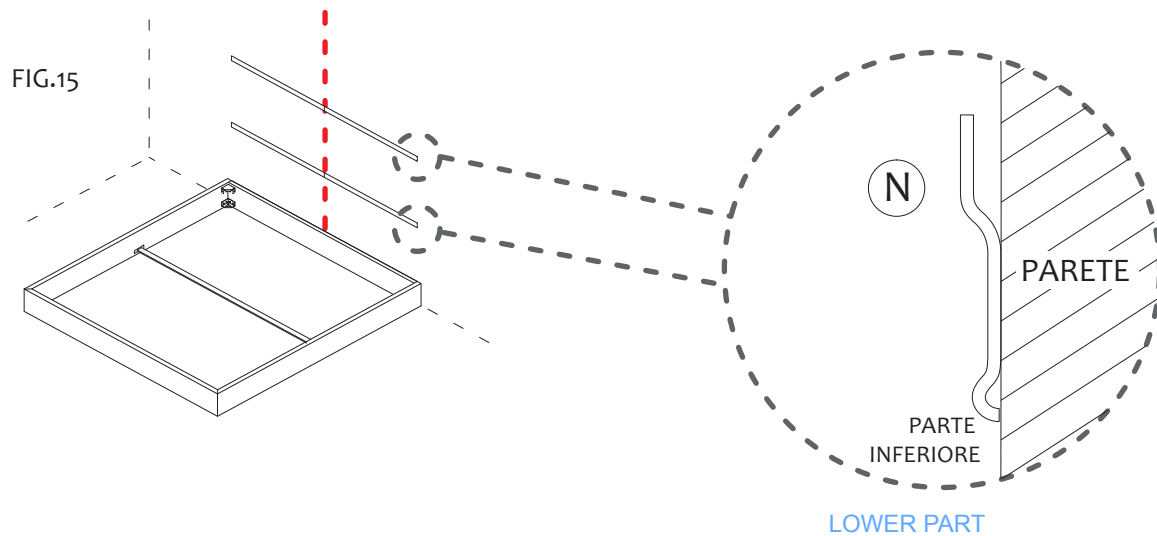
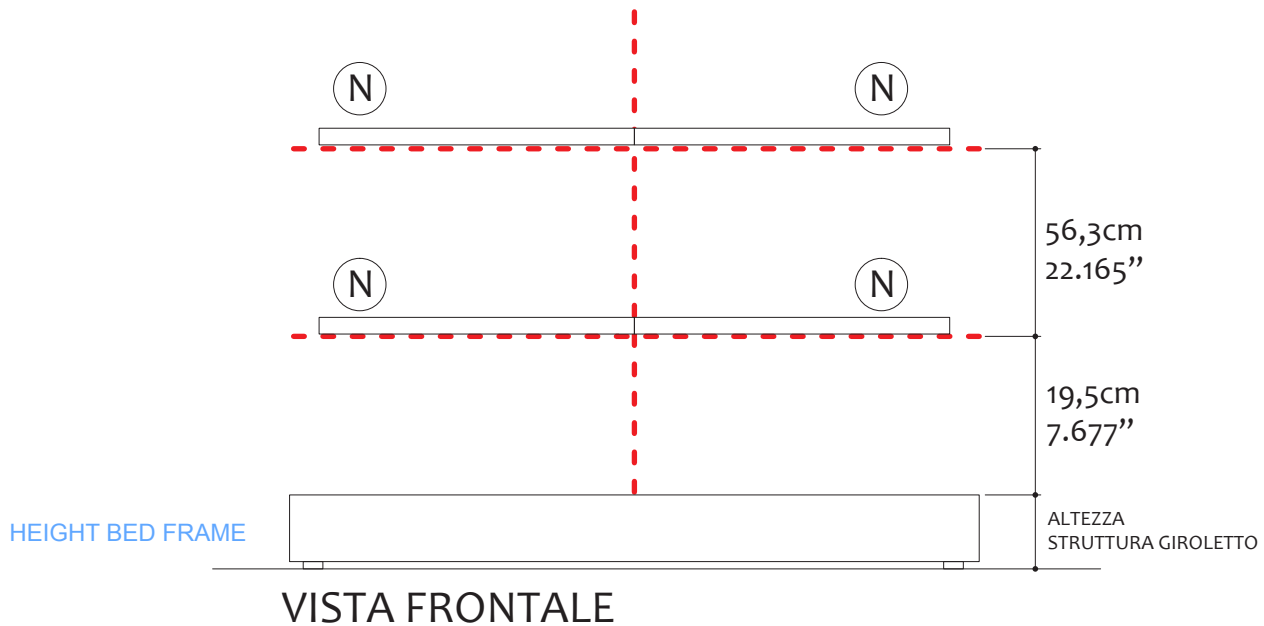

FIG.16



POSITION THE FIRST TWO WALL BRACKETS, CAREFULLY TO ORIENT THEM CORRECTLY (FIG.15). POSITION THESE BRACKETS ON ONE OF THE TWO HORIZONTAL LINES, MAKING THIS LINE COINCIDE WITH THE LOWER PART OF THE BRACKETS. MAKING THEM COINCIDE IN THE MIDDLE, POSITION ONE TO THE RIGHT AND ONE TO THE LEFT OF THE VERTICAL LINE. FASTEN THESE BRACKETS WITH WALL MOUNTING SCREWS, WHICH ARE NOT SUPPLIED. USE SCREWS AND DOWELS SUITABLE FOR THE FIXING WALL.

REPEAT THE OPERATION WITH THE OTHER TWO BRACKETS ON THE OTHER HORIZONTAL LINE.

POSIZIONARE LE PRIME DUE STAFFE A MURO PRESTANDO ATTENZIONE A ORIENTARLE CORRETTAMENTE (FIG.15). POSIZIONARE TALI STAFFE SU UNA DELLE DUE LINEE ORIZZONTALI, FACENDO COINCIDERE TALE LINEA CON LA PARTE INFERIORE DELLE STAFFE. FACENDOLE COINCIDERE AL CENTRO, POSIZIONARNE UNA A DESTRA E UNA A SINISTRA DELLA LINEA VERTICALE. FISSARE TALI STAFFE CON VITI PER FISSAGGIO A MURO NON FORNITE. UTILIZZARE VITI E TASSELLI ADATTI ALLA PARETE DI FISSAGGIO. RIPETERE L'OPERAZIONE CON LE ALTRE DUE STAFFE SULL'ALTRA LINEA ORIZZONTALE.

# ISTRUZIONI / INSTRUCTIONS

**nicoline**

SCHEDA MONTAGGIO LETTO  
LEGS ASSEMBLY INSTRUCTIONS BED

LM13

LETTO MOZART

FIG.17

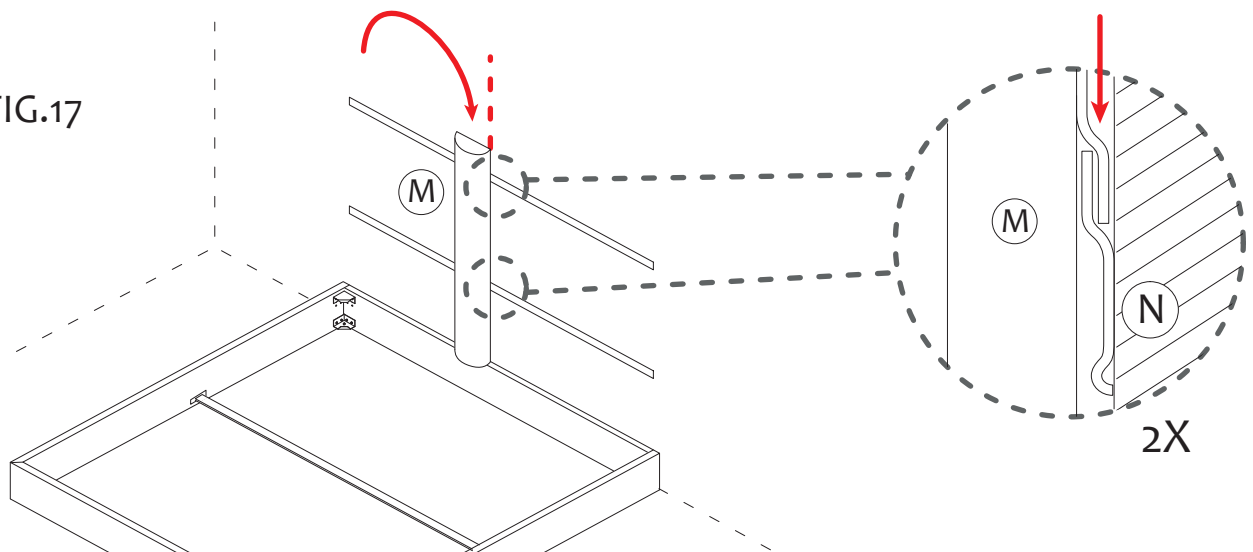

FIT THE FIRST PANEL TO THE TWO BRACKETS BY MATCHING THE LATERAL SIDE EDGE WITH THE CENTRE OF THE BED WIDTH.

NB. IF THE PANELS TO BE FITTED ARE ODD NUMBERED, MAKE THE CENTRE OF THE PANEL COINCIDE WITH THE CENTRE OF THE BED.

INCASTRARE IL PRIMO PANNELLO ALLE DUE STAFFE FACENDO COINCIDERE IL BORDO LATERALE DESTRO CON IL CENTRO DELLA LARGHEZZA DEL LETTO.

NB. NEL CASO IN CUI I PANNELLI DA MONTARE FOSSERO DISPARI FAR COINCIDERE IL CENTRO DEL PANNELLO CON IL CENTRO DEL LETTO.

FIG.18

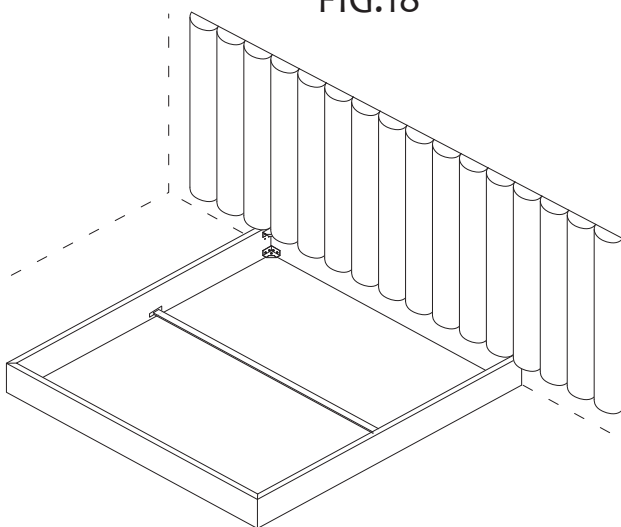
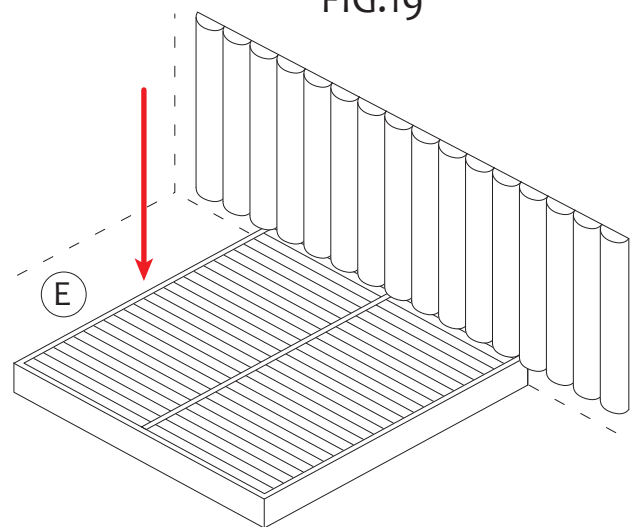

FIG.19



FIT THE REST OF THE PANELS, REPEATING THE OPERATION DESCRIBED ABOVE (SEE FIG. 18).  
COVER THE FRAME WITH THE FABRIC (IN THE CASE OF THE REMOVABLE VERSION)  
AND PLACE THE BED BASE INSIDE THE BED FRAME (SEE FIG.19).

INCASTRARE IL RESTO DEI PANNELLI RIPETENDO L'OPERAZIONE PRECEDENTEMENTE DESCRITTA (VEDI FIG.18).  
RIVESTIRE LA STRUTTURA CON IL TESSUTO (NEL CASO DELLA VERSIONE SFODERABILE)  
E ALLOGGIARE LA RETE LETTO ALL'INTERNO DEL GIROLETTO (VEDI FIG.19).